

CONTENTS

1.	SAFETY INSTRUCTIONS	3
2.	SAFETY LABEL LOCATIONS	5
	CE mark and noise label locations	6
3.	COMPONENT IDENTIFICATION	7
4.	PRE-OPERATION CHECK	12
5.	STARTING THE ENGINE	16
	• High altitude operation	
6.	GENERATOR USE	19
7.	STOPPING THE ENGINE	24
8.	MAINTENANCE	25
9.	TRANSPORTING/STORAGE	34
10.	TROUBLESHOOTING	35
11.	OPTIONAL PARTS	37
12.	SPECIFICATIONS	41
13.	WIRING DIAGRAM	44
14.	MAJOR Honda DISTRIBUTOR ADDRESSES	49

Honda EX3300S•4000S•4500S

OWNER'S MANUAL



ECOLOGY CONSCIOUS TECHNOLOGY

The "e-SPEC" mark symbolizes environmentally responsible technologies applied to Honda power equipment, which contains our wish to "preserve nature for generations to come."

Thank you for purchasing a Honda generator.

This manual covers operation and maintenance of the EX3300S, EX4000S and EX4500S generators.

All information in this publication is based on the latest production information available at the time of printing.

Honda Motor Co., Ltd. reserves the right to make changes at any time without notice and without incurring any obligation.

No part of this publication may be reproduced without written permission.

This manual should be considered a permanent part of the generator and should remain with it if it is resold.

Pay special attention to statements preceded by the following words:

⚠ WARNING Indicates a strong possibility of severe personal injury or death if instructions are not followed.

CAUTION: Indicates a possibility of personal injury or equipment damage if instructions are not followed.

NOTE: Gives helpful information.

If a problem should arise, or if you have any questions about the generator, consult an authorized Honda dealer.

⚠ WARNING The Honda generator is designed to give safe and dependable service if operated according to instructions.

Read and understand this Owner's Manual before operating the generator. Failure to do so could result in personal injury or equipment damage.

- The illustration may vary according to the type.

1. SAFETY INSTRUCTIONS

⚠ WARNING

To ensure safe operation-



- Honda generator is designed to give safe and dependable service if operated according to instructions.
Read and understand the Owner's Manual before operating the generator. Failure to do so could result in personal injury or equipment damage.



- Exhaust gas contains poisonous carbon monoxide. Never run the generator in an enclosed area. Be sure to provide adequate ventilation. When installed in ventilated protection are to be observed.



- The muffler becomes very hot during operation and remains hot for a while after stopping the engine. Be careful not to touch the muffler while it is hot. Let the engine cool before storing the generator indoors.
- The engine exhaust system will be heated during operation and remain hot immediately after stopping the engine.
To prevent scalding, pay attention to the warning marks attached to the generator.



- Gasoline is extremely flammable and explosive under certain conditions. Refuel in a well ventilated area with the engine stopped.
- Keep away from cigarette, smoke and sparks when refueling the generator. Always refuel in a well-ventilated location.
- Wipe up spilled gasoline at once.

Safety Instruction

▲ WARNING

To ensure safe operation —



- Connections for standby power to a building's electrical system must be made by a qualified electrician and must comply with all applicable laws and electrical codes. Improper connections can allow electrical current from the generator to back feed into the utility lines. Such back feed may electrocute utility company workers or others who contact the lines during a power outage, and when utility power is restored, the generator may explode, burn, or cause fires in the building's electrical system.

- Always make a pre-operation inspection (page 12) before you start the engine. You may prevent an accident or equipment damage.
- Place the generator at least 1 m (3 ft) away from buildings or other equipment during operation.
- Operate the generator on a level surface.
If the generator is tilted, fuel spillage may result.
- Know how to stop the generator quickly and understand operation of all the controls. Never permit anyone to operate the generator without proper instructions.
- Keep children and pets away from the generator when it is in operation.
- Keep away from rotating parts while the generator is running.
- The generator is a potential source of electrical shocks when misused; do not operate with wet hands.
- Do not operate the generator in rain or snow and do not let it get wet.

2. SAFETY LABEL LOCATIONS

EX4000S: B, F, G, GW, IT types

These labels warn you of potential hazards that can cause serious injury. Read the labels and safety notes and precautions described in this manual carefully.

If a label comes off or becomes hard to read, contact your Honda dealer for a replacement.

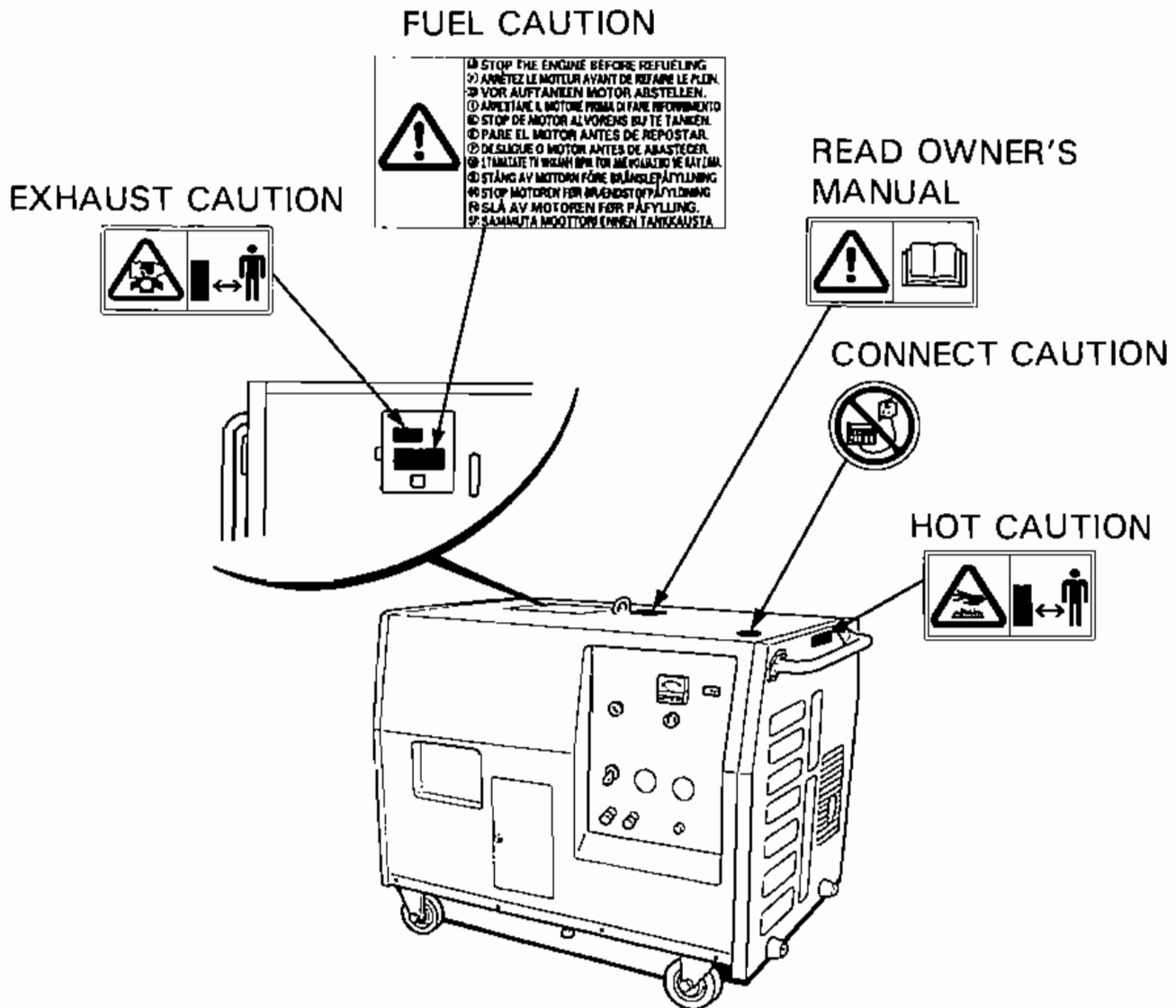

CE mark and noise label locations
EX4000S: B, F, G, GW, IT types

NOISE LABEL

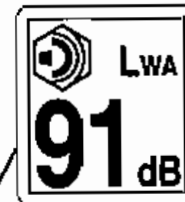

[Example: EX4000S
NOISE LABEL]

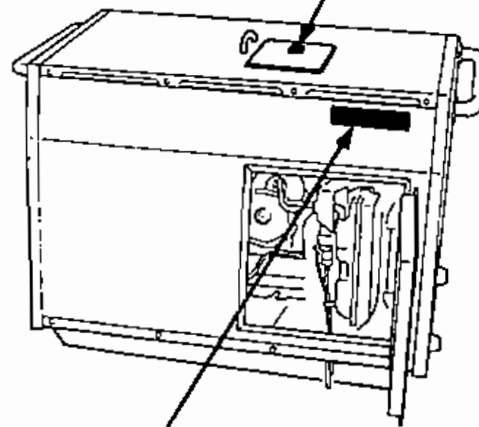

CE MARK

CE	Generating set		EX4000S		Performance class G1
	ISO 8528		Honda Motor Co., Ltd.		
	Rated power COP	3.5 kW	50 Hz	Max. 40 °C	
	Rated power factor	1.0	115V/230V	Max. 1000 m	
Year of Mfg.	30.4A/15.2A	Max. 122 kg	IP23S		IP code

Manufacturer and address: 2-1-1 Minamilaoyama, Minato-ku, Tokyo, Japan

Maximum ambient temperature: 40 °C

Maximum altitude: 1000 m

Dry weight: 122 kg

[Example: EX4000S CE MARK]

3. COMPONENT IDENTIFICATION

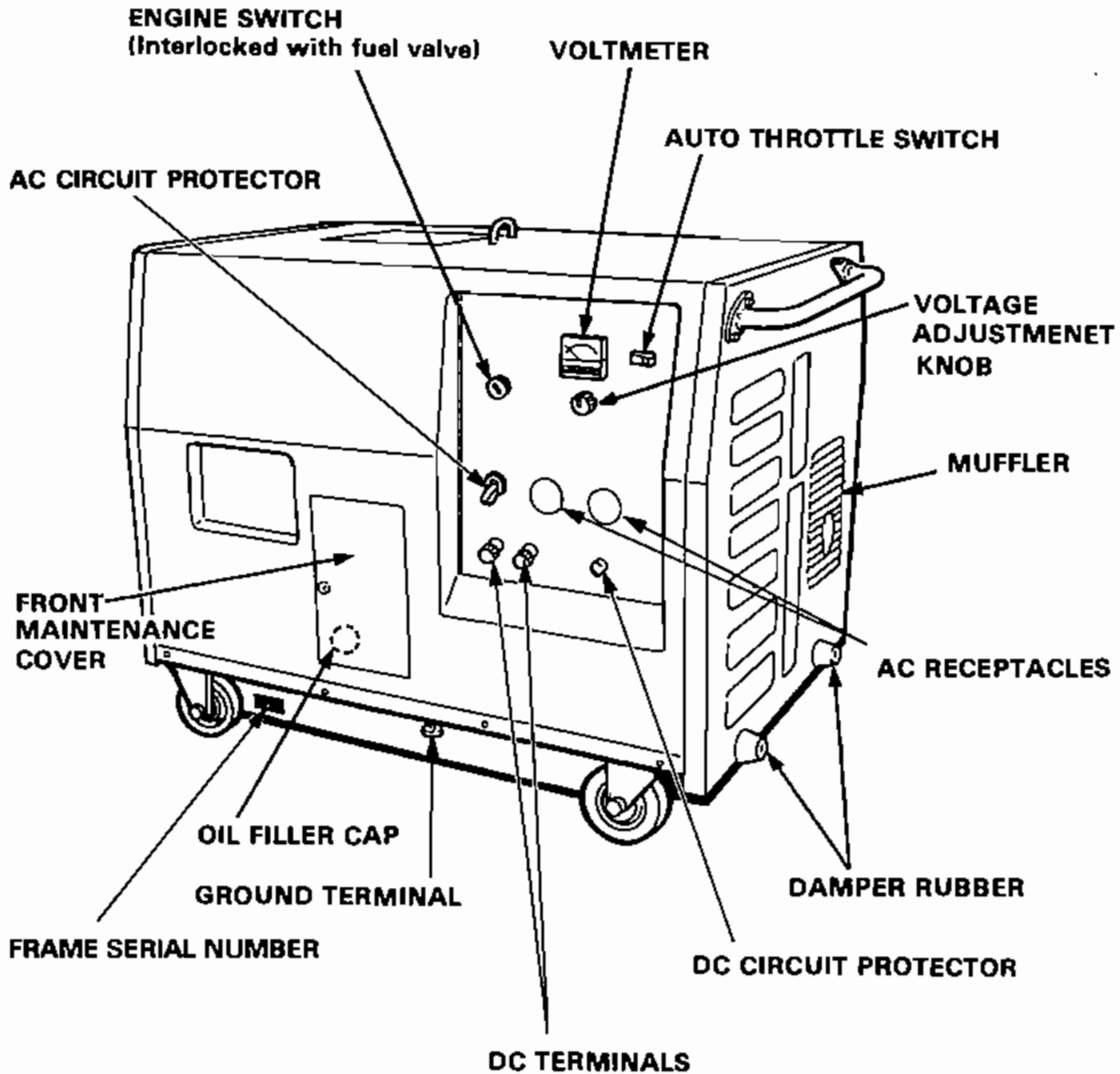

Record the frame serial number in the space below.
You will need this serial number when ordering parts.

Frame serial number: _____

F type

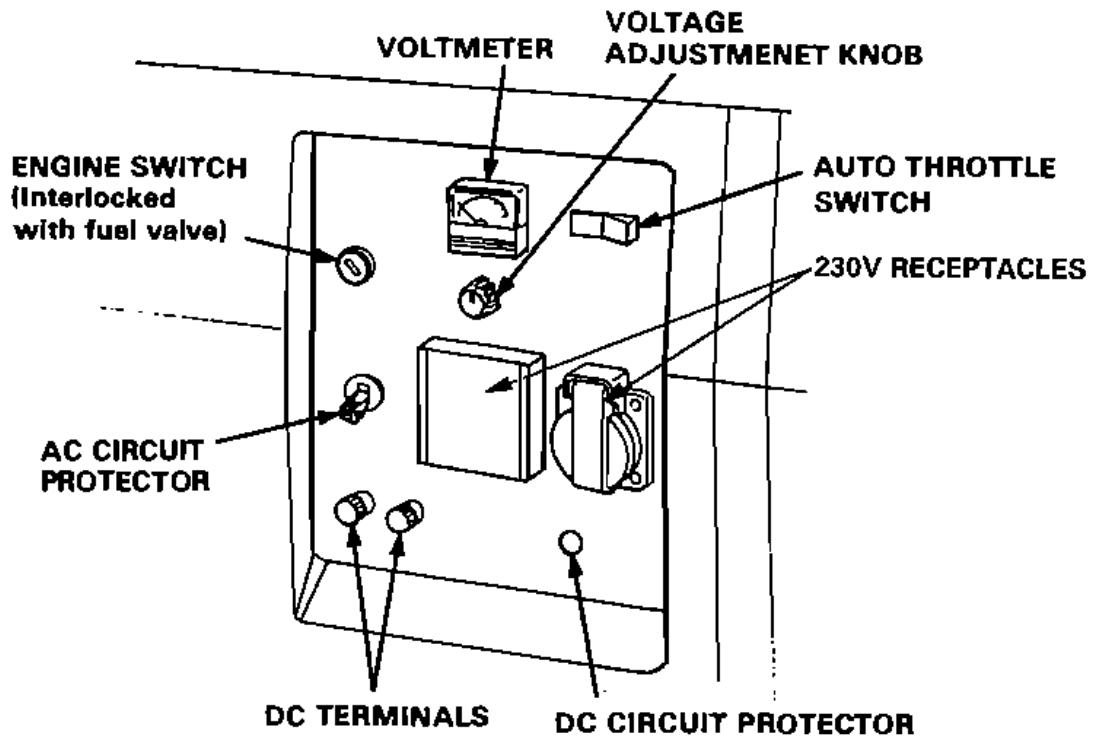

G, GW type

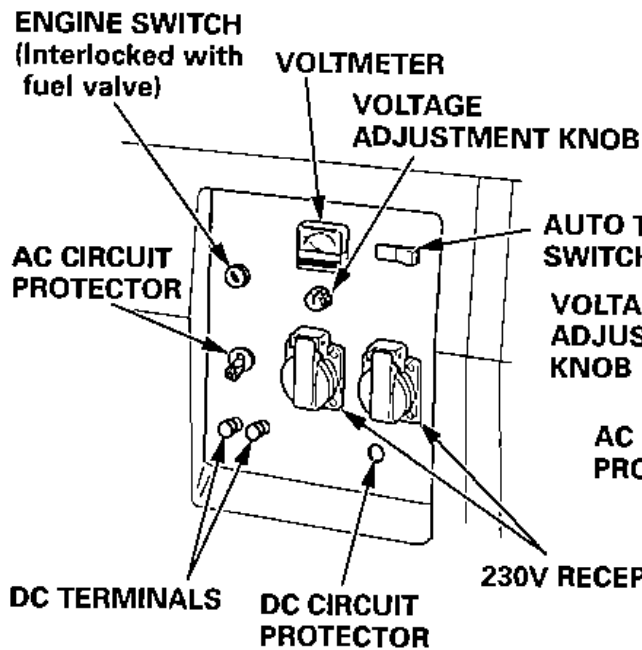

IT type

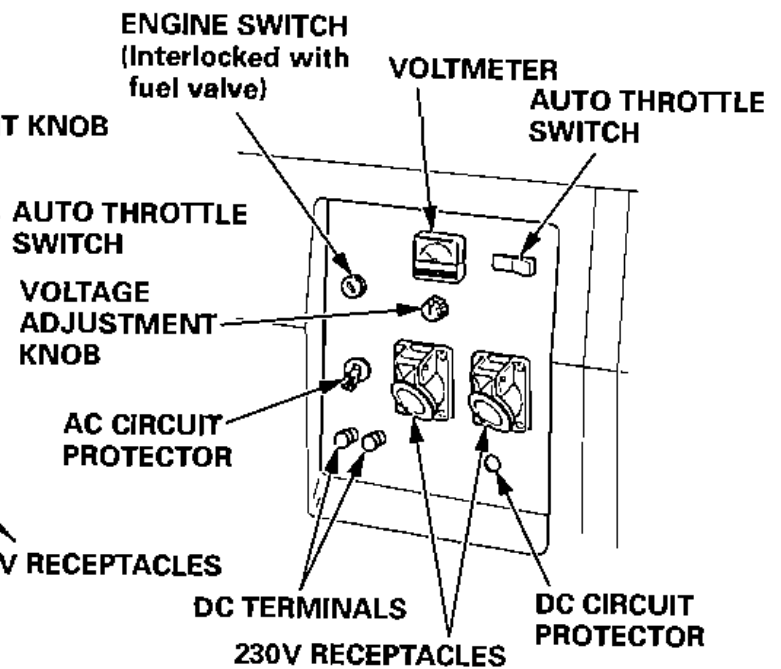

B type

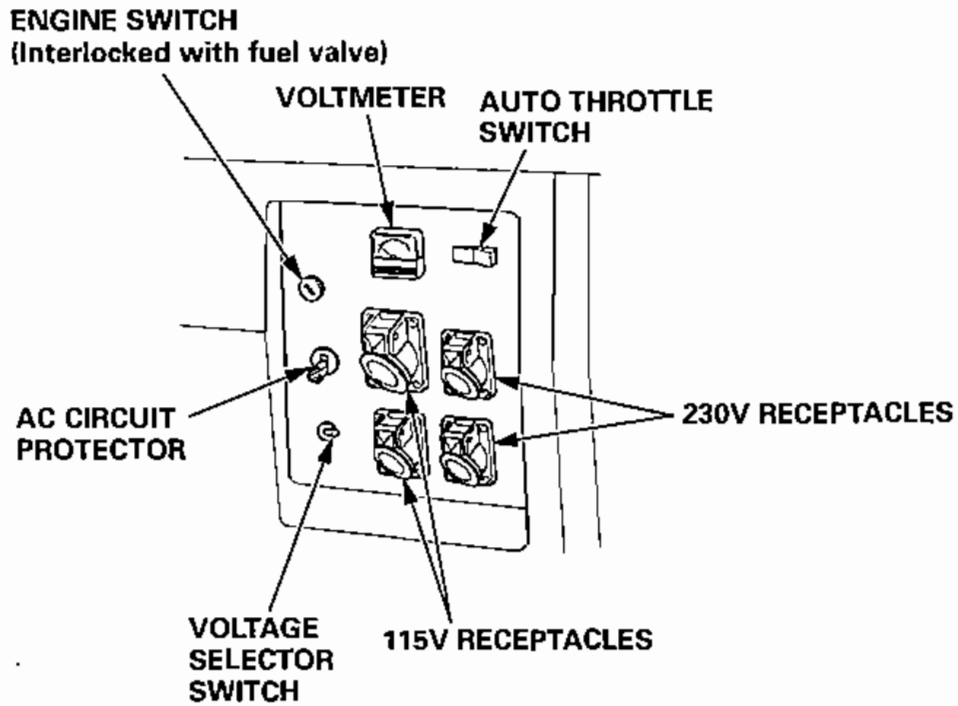

L type

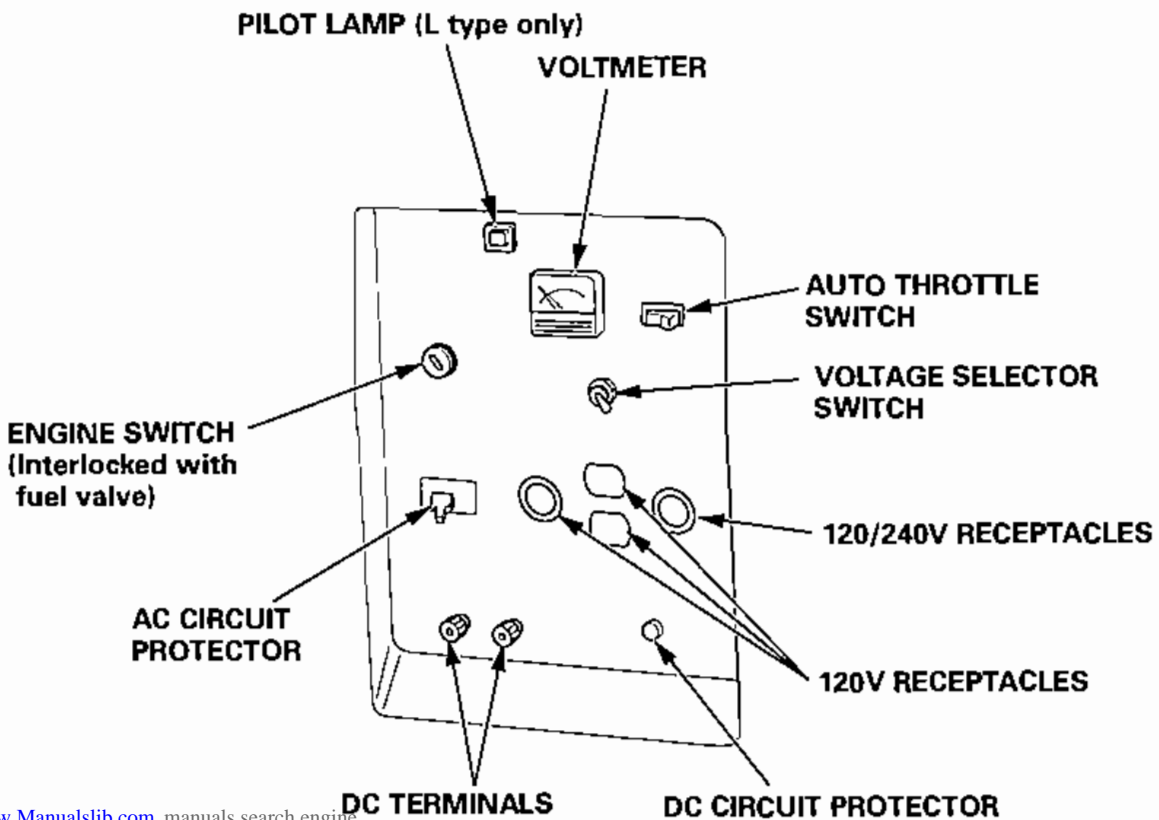

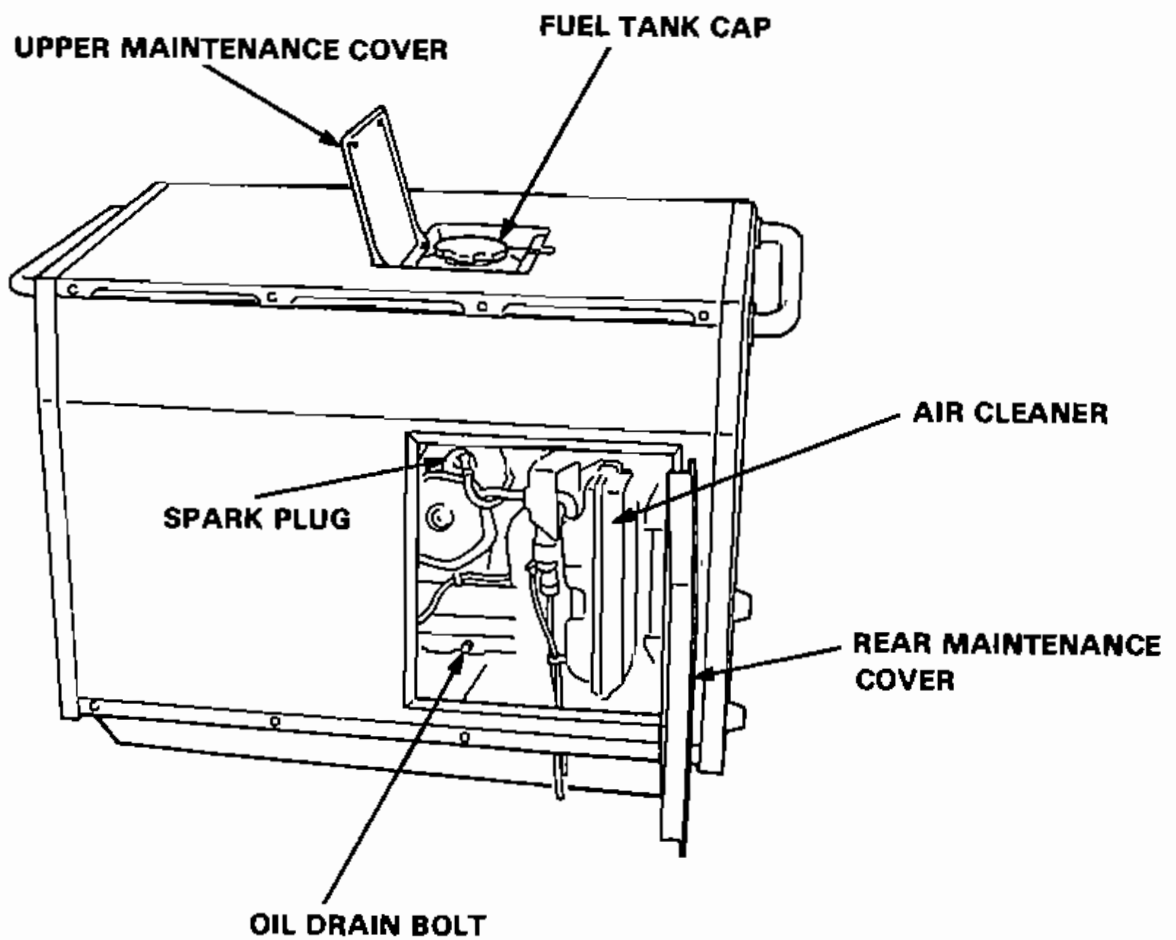

Auto throttle

AUTO:

Engine speed is kept at idle automatically when the electrical appliance is disconnected and it returns to the rated speed when electrical appliance is connected.

NOTE:

- This position is recommended to minimize the fuel consumption while in operation.
- Auto throttle system does not work when the electrical load is less than 1 A.
- Auto throttle system does not operate sufficiently if the electrical appliance requires the momentary electric power.
- Warming up the engine with this system on may require a longer period than usual.

OFF:

Auto throttle system does not operate.

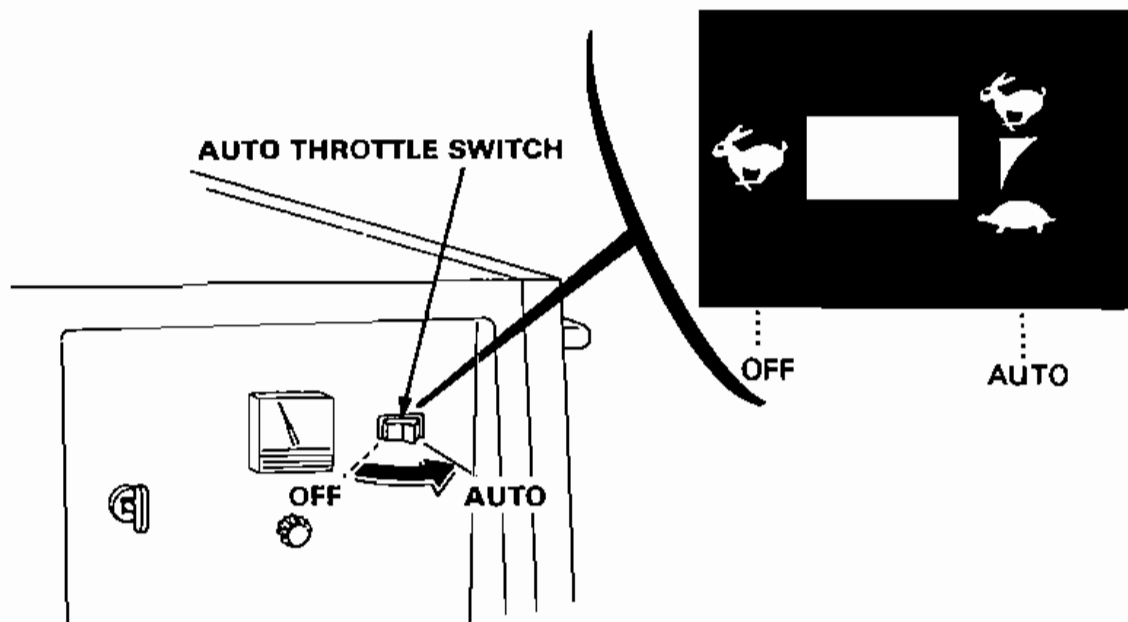

4. PRE-OPERATION CHECK

CAUTION: Be sure to check the generator on a level surface with the engine stopped.

1. Check the engine oil level.

CAUTION: Using nondetergent oil or 2-stroke engine oil could shorten the engine's service life.

Use Honda 4-stroke oil, or an equivalent high detergent premium quality motor oil, certified to meet or exceed U.S. auto-mobile manufacturer's requirements for API Service Classification SG, SF. (motor oils classified SG, SF will show this designation on the container.)

SAE 10W/30 is recommended for general, all-temperature use. Other viscosities shown in the chart may be used when the average temperature in your area is within the indicated range.

Select the appropriate viscosity for the average temperature in your area.

Remove the oil filler cap, and wipe the dipstick with a clean rag. Check the oil level by inserting the dipstick in the filler hole without screwing it in.

If the oil level is low, fill to the top of the oil filler neck with the recommended oil.

NOTE: The Oil Alert System will automatically stop the engine before the oil level falls below the safe limit. However, to avoid the inconvenience of an unexpected shutdown, it is still advisable to visually inspect the oil level regularly.

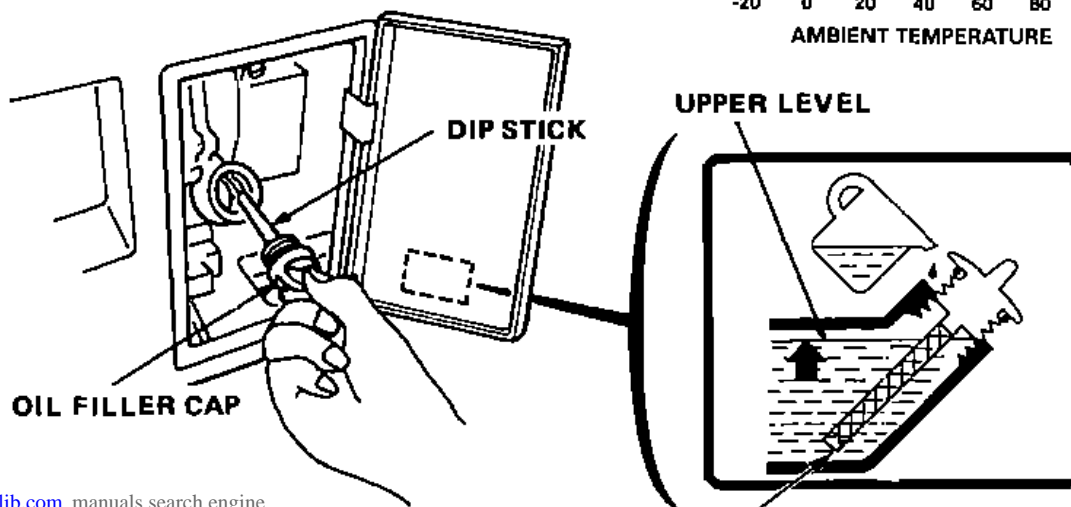
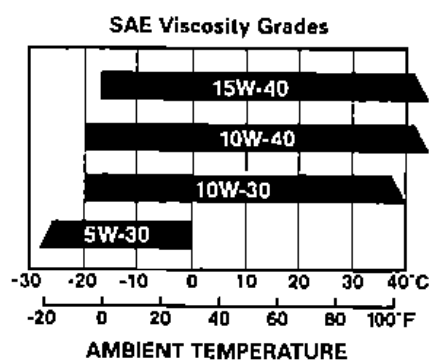

2. Check the fuel level.

If the fuel level is low, refill the shoulder of the fuel strainer.

Use automotive unleaded gasoline with a Research Octane Number of 91 or higher (a Pump Octane Number of 86 or higher).

Never use stale or contaminated gasoline or an oil/gasoline mixture. Avoid getting dirt or water in the fuel tank.

After refueling, tighten the fuel tank cap securely.

▲ WARNING

- Gasoline is extremely flammable and is explosive under certain conditions.
- Refuel in a well-ventilated area with the engine stopped. Do not smoke or allow flames or sparks in the area where the engine is refueled or where gasoline is stored.
- Do not overfill the fuel tank (there should be no fuel in the filler neck). After refueling, make sure the tank cap is closed properly and securely.
- Be careful not to spill fuel when refueling. Spilled fuel or fuel vapor may ignite. If any fuel is spilled, make sure the area is dry before starting the engine.
- Avoid repeated or prolonged contact with skin or breathing of vapor. **KEEP OUT OF REACH OF CHILDREN.**

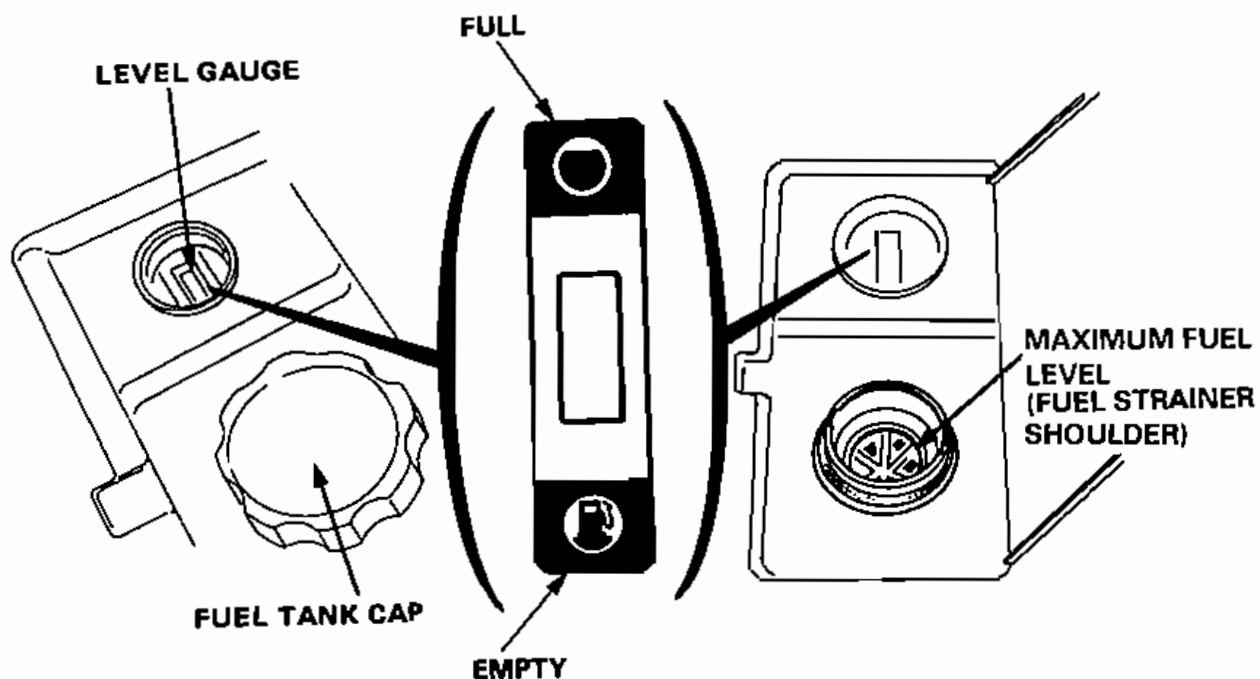

NOTE:

Gasoline spoils very quickly depending on factors such as light exposure, temperature and time.

In worst cases, gasoline can be contaminated within 1 month.

Using contaminated gasoline can seriously damage the engine (clogged carburetor, stuck valve).

Such damage due to spoiled fuel is disallowed from coverage by the warranty.

To avoid this please strictly follow these recommendations:

- Only use specified gasoline (see page 13).
- To slow deterioration, keep gasoline in a certified fuel container.
- If long storage (more than 1 month) is foreseen, drain fuel tank and carburetor.

Gasolines containing alcohol

If you decide to use a gasoline containing alcohol (gasohol), be sure it's octane rating is at least as high as that recommended by Honda. There are two types of "gasohol": one containing ethanol, and the other containing methanol. Do not use gasohol that contains more than 10% ethanol. Do not use gasoline containing methanol (methyl or wood alcohol) that does not also contain cosolvents and corrosion inhibitors for methanol. Never use gasoline containing more than 5% methanol, even if it has cosolvents and corrosion inhibitors.

NOTE:

- Fuel system damage or engine performance problems resulting from the use of fuels that contain alcohol is not covered under the warranty. Honda cannot endorse the use of fuels containing methanol since evidence of their suitability is as yet incomplete.
- Before buying fuel from an unfamiliar station, try to find out if the fuel contains alcohol, if it does, confirm the type and percentage of alcohol used. If you notice any undesirable operating symptoms while using a gasoline that contains alcohol, or one that you think contains alcohol, switch to a gasoline that you know does not contain alcohol.

3. Check the air cleaner.

Check the air cleaner element to be sure it is clean and in good condition. Clean or replace the element if necessary (page 27).

CAUTION: Never run the engine without the air cleaner. Rapid engine wear will result from contaminants, such as dust and dirt, being drawn through the carburetor into the engine.

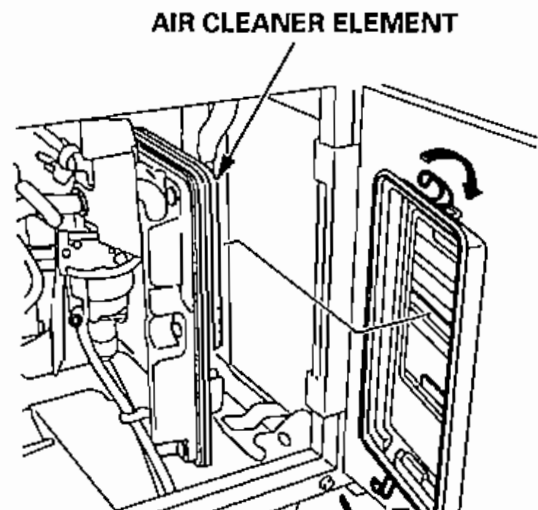

4. Check the battery.

The electrolyte level must be maintained between the UPPER and LOWER level marks. If the electrolyte level is near the LOWER mark, add distilled water.

⚠ WARNING

- **Batteries produce explosive gases: If ignited, and explosion can cause serious injury or blindness. Provide adequate ventilation when charging.**
- **CHEMICAL HAZARD: Battery electrolyte contains sulfuric acid. Contact with eyes or skin, even through clothing, may cause severe burns. Wear a faceshield and protective clothing.**
- **Keep flames and sparks away, and do not smoke in the area.**
- **ANTIDOTE: If electrolyte gets into your eyes, flush thoroughly with warm water for at least 15 minutes and call a physician immediately.**
- **POISON: Electrolyte is poison.**
ANTIDOTE:
 - **External: Flush thoroughly with water.**
 - **Internal: Drink large quantities of water or milk.**
Follow with milk of magnesia or vegetable oil, and call a physician immediately.
- **KEEP OUT OF REACH OF CHILDREN.**

CAUTION:

- **Use only distilled water in the battery. Tap water will shorten the service life of the battery.**
- **Filling the battery above the UPPER LEVEL line may cause the electrolyte to overflow, resulting in corrosion to engine or nearby parts. Immediately wash off any spilled electrolyte.**

Check the battery terminals to be sure the cables are tightened and free of corrosion. Remove any corrosion and coat the terminals and cable ends with grease.

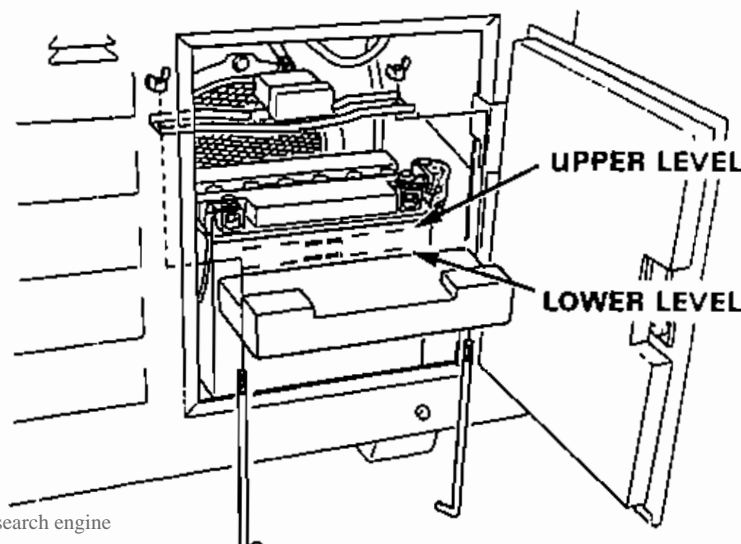

5. STARTING THE ENGINE

ELECTRIC STARTING

CAUTION: When starting the generator after adding fuel for the first time, after long-term storage, or after running out of fuel, turn the engine switch to the "ON" position, then wait for 10 to 20 seconds before starting the engine.

Before starting the engine disconnect any load from the AC receptacle and DC terminals.

1. Turn off the AC circuit protector.

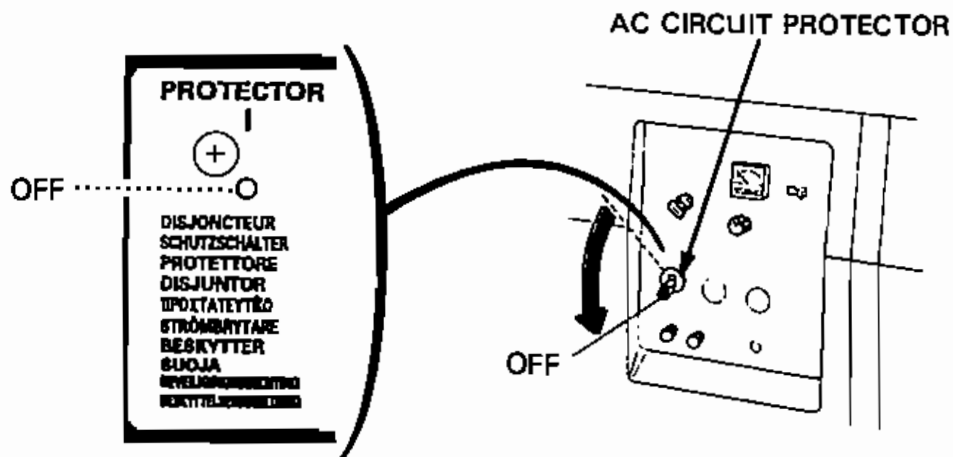

2. Make sure the auto-throttle switch is off, or more time will be required for warming up.

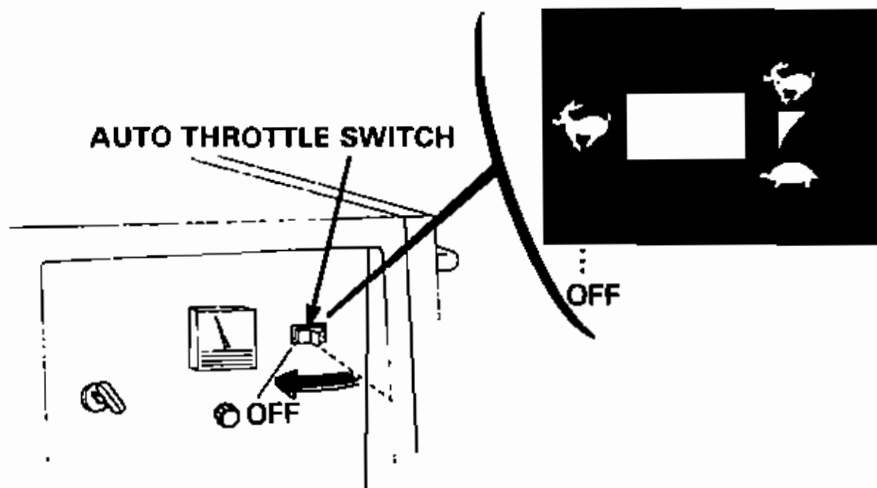

3. Turn the engine switch to START and hold it there until the engine starts.

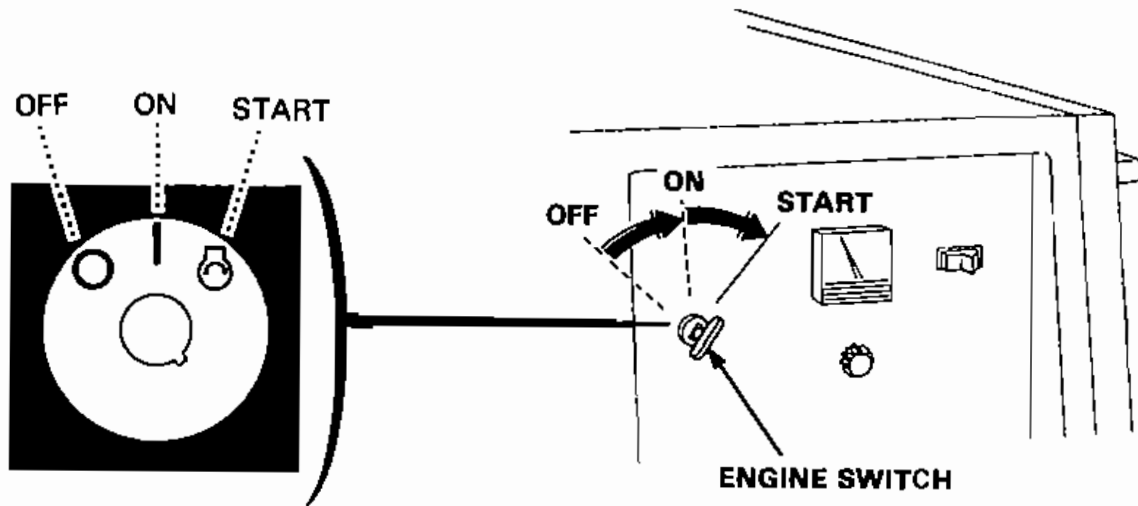

CAUTION: Do not use the starter motor for more than 5 seconds. If the engine fails to start, release the key, and wait at least 10 seconds before operating the starter motor again.

NOTE: When the speed of the starter motor drops after a period of time, it is an indication that the battery should be recharged.

4. After the engine starts, let the engine switch return to ON.

5. Turn the auto-throttle switch to AUTO after the engine is warmed up.

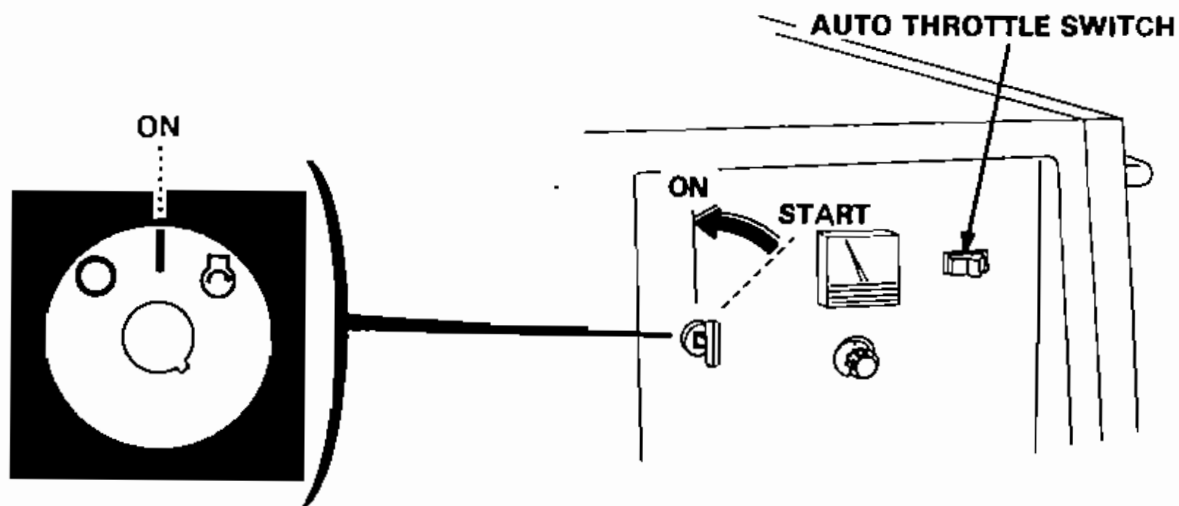

NOTE: The generator employs an automatic choke when the starter motor and battery are used.

- **High altitude operation**

At high altitude, the standard carburetor air-fuel mixture will be excessively rich. Performance will decrease, and fuel consumption will increase.

High altitude performance can be improved by specific modifications to the carburetor. If you always operate the generator at altitudes higher than 1,500 m (5,000 feet) above sea level, have your authorized Honda dealer perform these carburetor modifications.

Even with suitable carburetor jetting, engine horsepower will decrease approximately 3.5% for each 300-meter (1,000-foot) increase in altitude. The affect of altitude on the horse power will be greater than this if no carburetor modification is made.

CAUTION: Operation of the generator at an altitude lower than the carburetor is jetted for may result in reduced performance, overheating, and serious engine damage caused by an excessively lean air/fuel mixture.

6. GENERATOR USE

Be sure to ground the generator when the connected equipment is grounded.

⚠ WARNING

Connections for standby power to a building's electrical system must be made by a qualified electrician and must comply with all applicable laws and electrical codes. Improper connections can allow electrical current from the generator to backfeed into the utility lines. Such backfeed may electrocute utility company workers or others who contact the lines during a power outage, and when utility power is restored, the generator may explode, burn, or cause fires in the building's electrical system.

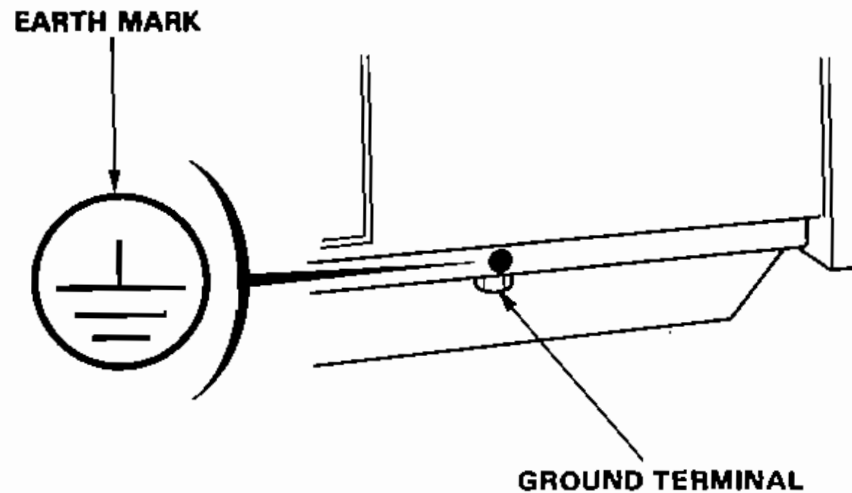

CAUTION

- Limit operation requiring maximum power (See page 41 and 42) to 30 minutes. For continuous operation, do not exceed the rated power (See page 41 and 42). In either case, the total wattage of all appliances connected must be considered.
- Most appliance motors require more than their rated wattage for start up.
- Use within the rated ampere.
- Do not exceed the current limit specified for any one receptacle.
- Do not connect the generator to a household circuit. This could cause damage to the generator or to electrical appliances in the house.

CAUTION:

- **Do not modify or use the generator for other purposes than it is intended for. Also observe the following when using the generator.**
 - **Do not connect generators in parallel.**
 - **Do not connect an extension to the exhaust pipel.**
 - **Set the generator in the correct AC frequency range (50 Hz or 60 Hz).**
- **When an extension cable is required, be sure to use a tough rubber sheathed flexible cable (IEC 245 or equivalent).**
- **Limit length of extension cables; 60 m for cables of 1.5 mm² and 100 m for cables of 2.5 mm². Long extension cables will lower usable power due to resistance in the extension cable.**
- **Keep the generator away from other electric cables or wires such as commercial power supply lines.**

AC applications

1. Start the engine and make sure the pilot lamp (L type only) comes on. If not, check the filament.
2. Choose the proper voltage by changing the voltage selector switch (B and L types only).
3. Switch on the AC Circuit protector.

NOTE:

- Although voltage adjustment is usually not required, fine adjustments may be made by turning the voltage adjustment knob. Use the generator at the specified voltage (Except B and L types).
- This generator cannot supply 115 V and 230 V (B type), 120 V and 240 V (L type) at the same time.
- The circuit protector button will pop out to show that the circuit protector has switched off. Push the button into reset the circuit protector.

4. Plug in the appliance.

CAUTION: Be sure that appliances do not exceed the generator's rated load capacity for more than 30 minutes and that they never exceed the maximum load capacity. Substantial overloading will switch off the circuit protector. Marginal overloading may not switch off the circuit protector, but it will shorten the service life of the generator.

Be sure that all appliances are in good working order before connecting them to the generator. If an appliance begins to operate abnormally, becomes sluggish, or stops suddenly, turn off the circuit protector and the generator engine switch immediately. Then disconnect the appliance and examine it for signs of malfunction.

NOTE: If an overloaded circuit causes the AC circuit protector to switch off, reduce the electrical load on the circuit and wait a few minutes before resetting the circuit protector.

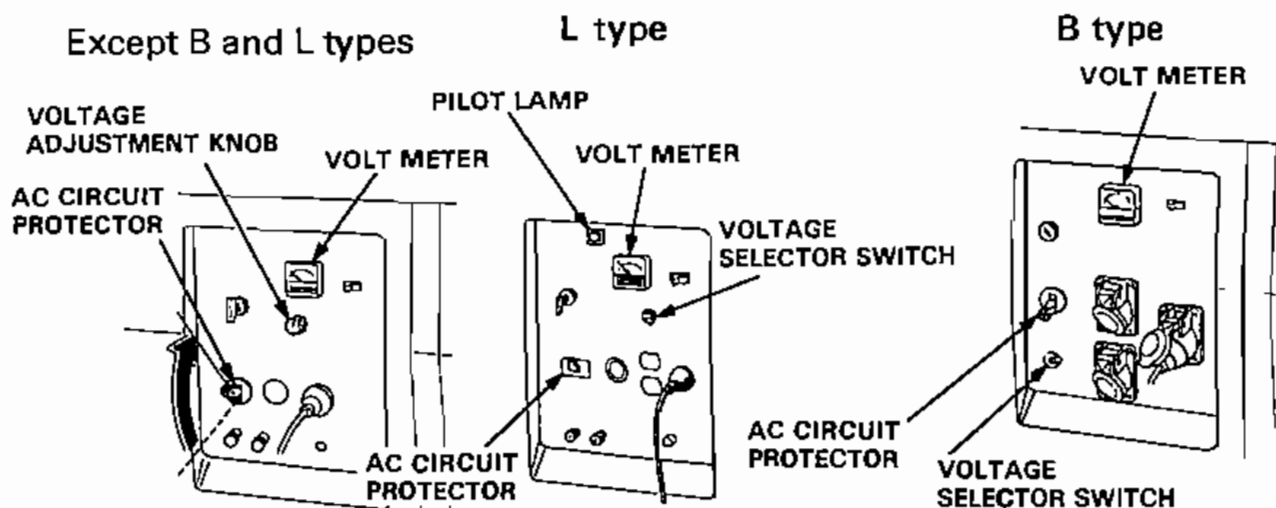

DC application (Except B type)

The DC terminals may be used for charging 12 volt automotive-type batteries only.

1. Connect the charging cables to the battery terminals and then to the DC terminals of the generator.

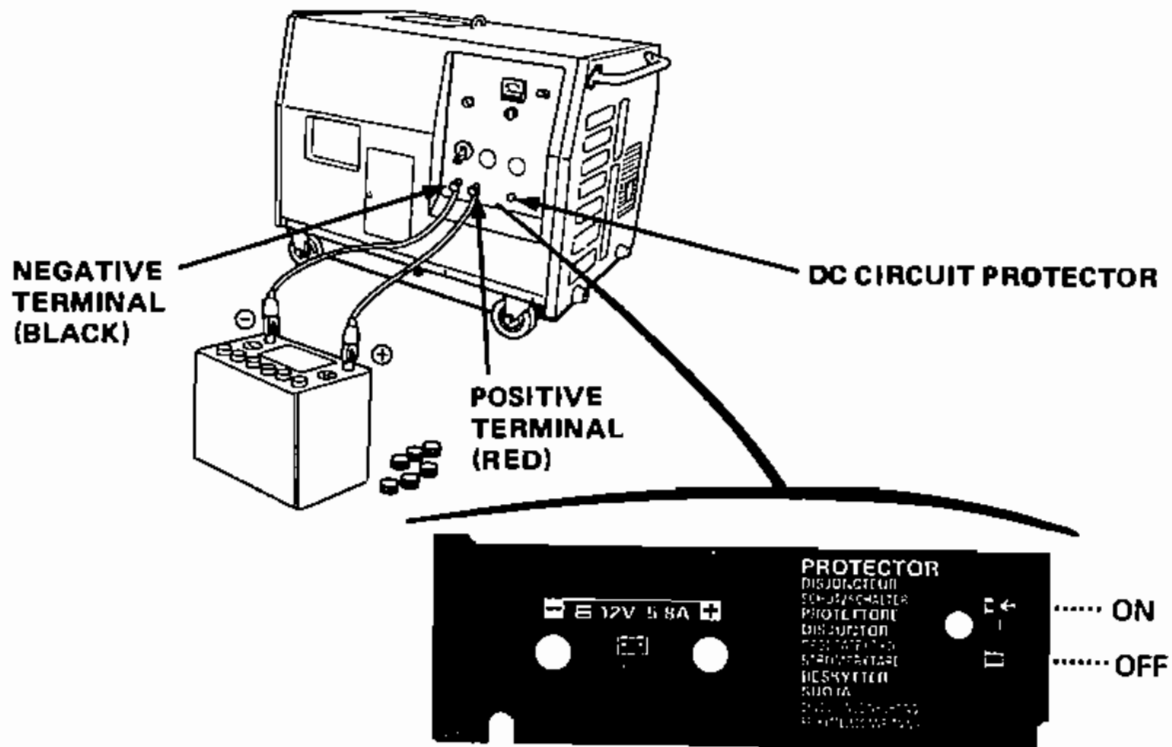

▲ WARNING

- To prevent the possibility of creating a spark near the battery, connect charging cables first to the battery, then to the generator. Disconnect cables first at the generator.
- Before connecting charging cables to a battery that is installed in a vehicle, disconnect the vehicle's grounded battery cable. Reconnect the vehicle's grounded battery cable after the charging cables are removed. This procedure will prevent the possibility of a short circuit and sparks if you make accidental contact between a battery terminal and the vehicle's frame or body.

CAUTION:

- Do not attempt to start an automobile engine with the generator still connected to the battery. The generator may be damaged.
- Connect the positive battery terminal to the positive charging cord. Do not reverse the charging cables, or serious damage to the generator and/or battery may occur.

⚠ WARNING

- **Batteries produce explosive gases: If ignited, and explosion can cause serious injury or blindness. Provide adequate ventilation when charging.**
- **CHEMICAL HAZARD: Battery electrolyte contains sulfuric acid. Contact with eyes or skin, even through clothing, may cause severe burns. Wear a faceshield and protective clothing.**
- **Keep flames and sparks away, and do not smoke in the area.**
- **ANTIDOTE: If electrolyte gets into your eyes, flush thoroughly with warm water for at least 15 minutes and call a physician immediately.**
- **POISON: Electrolyte is poison.**
ANTIDOTE:
 - **External: Flush thoroughly with water.**
 - **Internal: Drink large quantities of water or milk. Follow with milk of magnesia or vegetable oil, and call a physician immediately.**
- **KEEP OUT OF REACH OF CHILDREN.**

2. Start the engine.

NOTE:

- The DC terminals may be used while the AC power is in use.
- An overload DC circuit will trip the DC circuit protector (push button comes out). If this happens, wait a few minutes before pushing in the circuit protector to resume operation.

7. STOPPING THE ENGINE

To stop the engine in an emergency, turn the engine switch OFF.

1. Turn off the AC circuit protector.

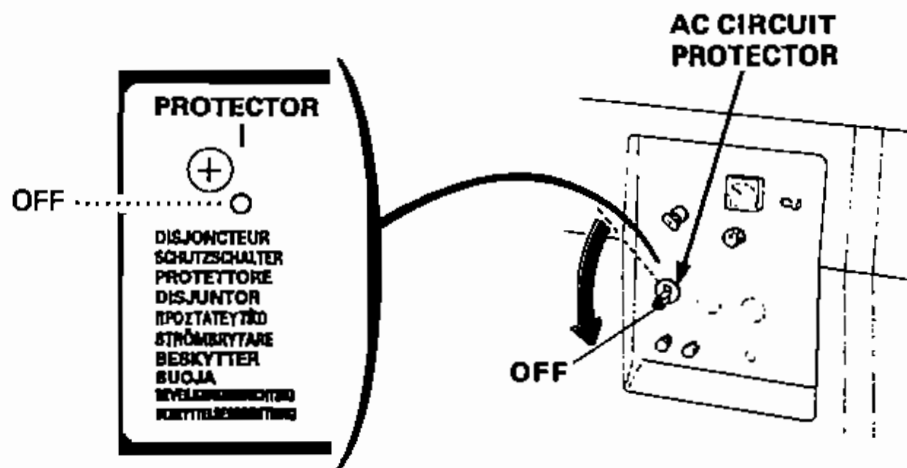

2. Turn off the engine switch.

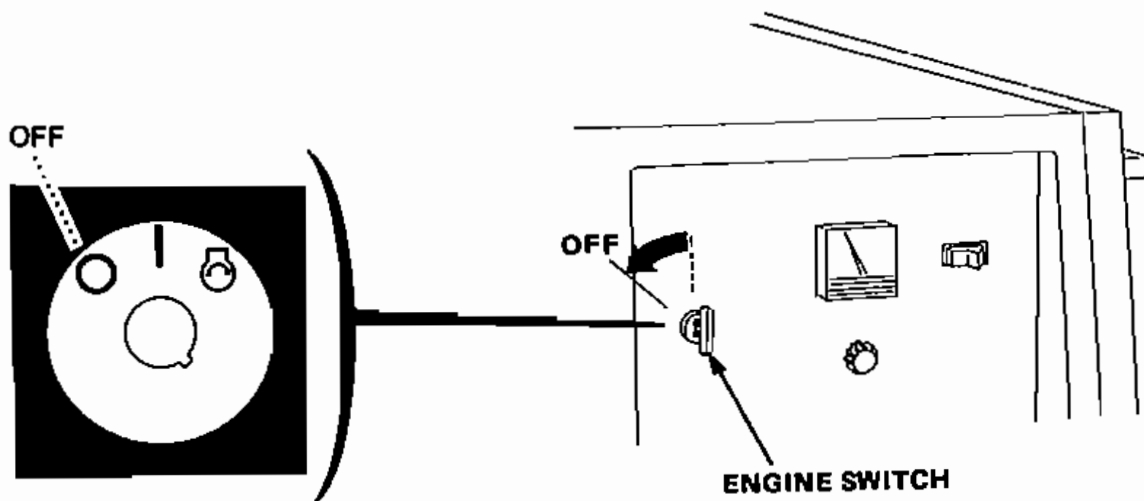

8. MAINTENANCE

The purpose of the maintenance and adjustment schedule is to keep the generator in the best operating condition.

Inspect or service as scheduled in the table below.

▲ WARNING Shut off the engine before performing any maintenance. If the engine must be run, make sure the area is well ventilated. The exhaust contains poisonous carbon monoxide gas.

CAUTION: Use genuine Honda parts or their equivalent. The use of replacement parts which are not of equivalent quality may damage the generator.

Maintenance Schedule

REGULAR SERVICE PERIOD (3) Perform at every indicated month or operating hour interval, whichever comes first.		Each use	First month or 20 hrs.	Every 3 months or 50 hrs.	Every 6 months or 100 hrs.	Every year or 300 hrs.
Item						
Engine oil	Check level	○				
	Change		○		○	
Air filter	Check	○				
	Clean			○(1)		
Battery electrolyte	Check level	○				
Sediment cup	Clean				○	
Spark plug	Check-adjust				○	
	Replace					○
Spark arrester (equipped type only)	Clean				○	
Valve Clearance	Check-adjust					○(2)
Combustion chamber	Clean	After every 500 hrs. (2)				
Fuel tank & filter	Clean				○(2)	
Fuel tube	Check	Every 2 years (Replace if necessary)(2)				

- NOTE: (1) Service more frequently when used in dusty areas.
 (2) These items should be serviced by your servicing dealer, unless you have the proper tools and are mechanically proficient. Refer to Honda shop manual for service procedures.
 (3) For commercial use, log hours of operation to determine proper maintenance intervals.

Changing oil

Drain the oil while the engine is still warm to assure rapid and complete draining.

1. Open the front maintenance cover.
2. Remove the drain bolt and filler cap, and drain the oil. Retighten the bolt securely.
3. Refill with the recommended oil (see page 12) and check the level.
4. Close and latch the front maintenance cover.

OIL CAPACITY: 1.1 l (1.16 US qt, 0.97 Imp qt)

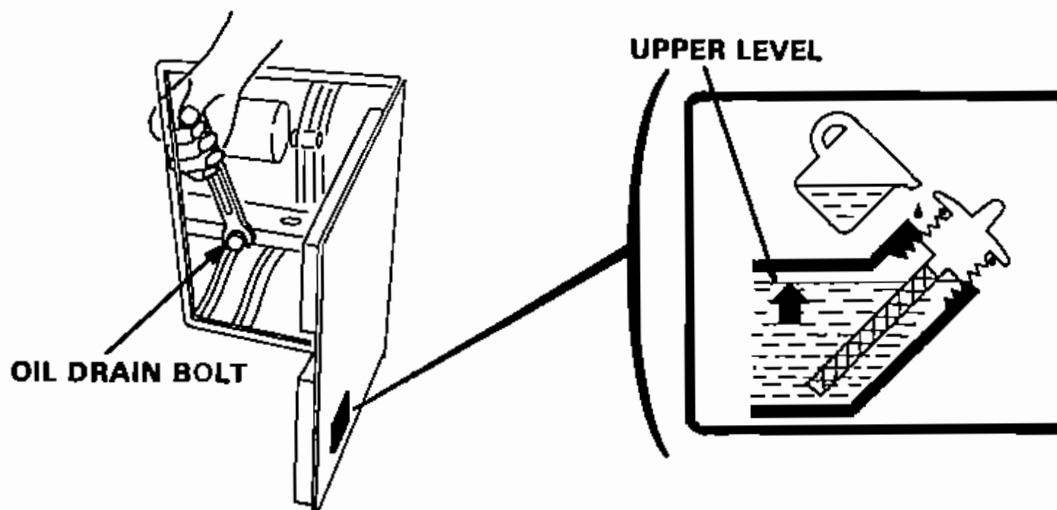

Wash your hands with soap and water after handling used oil.

NOTE: Please dispose of used motor oil in a manner that is compatible with the environment. We suggest you take it in a sealed container to your local service station for reclamation. Do not throw it in the trash or pour it on the ground.

Air cleaner service

A dirty air cleaner will restrict air flow to the carburetor. To prevent carburetor malfunction, service the air cleaner regularly. Service more frequently when operating the generator in extremely dusty areas.

⚠ WARNING Do not use gasoline or low flash point solvents for cleaning. They are flammable and explosive under certain conditions.

CAUTION: Never run the generator without the air cleaner. Rapid engine wear will result.

1. Open the rear maintenance cover.
2. Unsnap the clips, remove the air cleaner cover and air cleaner element.
3. Wash the element in a non flammable or high flash point solvent and dry it thoroughly.
4. Soak the element in clean engine oil and squeeze out the excess oil.
5. Reinstall the air cleaner element, the cover and snap the clip.
6. Close and latch the rear maintenance cover.

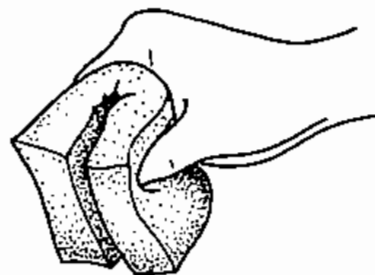
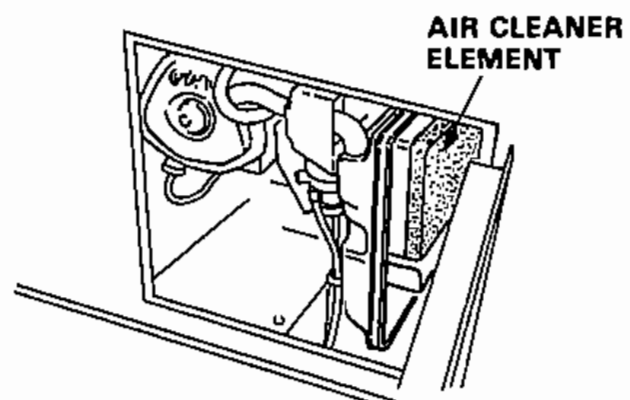
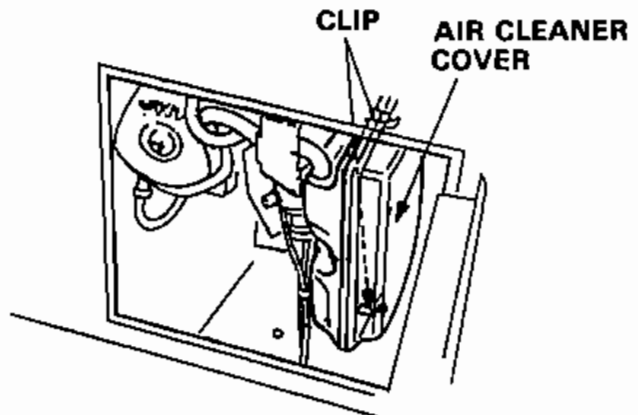

Spark plug service

Recommended spark plug: BPR5ES (NGK) W16EPR-U (DENSO)

To ensure proper engine operation, the spark plug must be properly gapped and free of deposits.

1. Open the rear maintenance cover.
2. Remove the spark plug cap.
3. Clean any dirt from around the spark plug base.
4. Use the wrench to remove the spark plug.

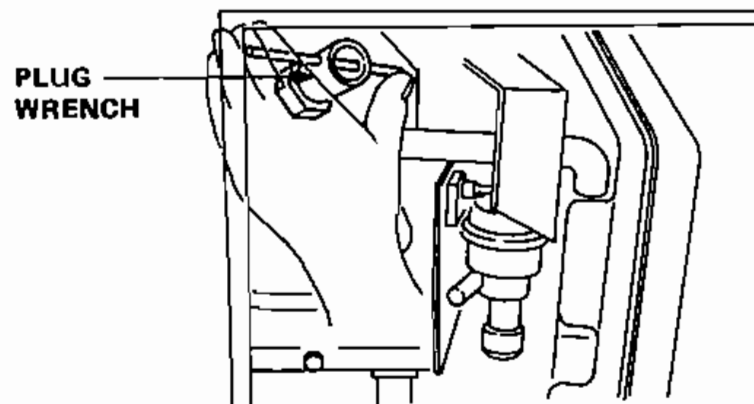

5. Visually inspect the spark plug. Discard the spark plug if there is apparent wear, or if the insulator is cracked or chipped. Clean the spark plug with a wire brush if it is to be reused.
6. Measure the plug gap with a feeler gauge.
The gap should be 0.7–0.8 mm (0.028–0.031 in).
Correct as necessary by carefully bending the side electrode.

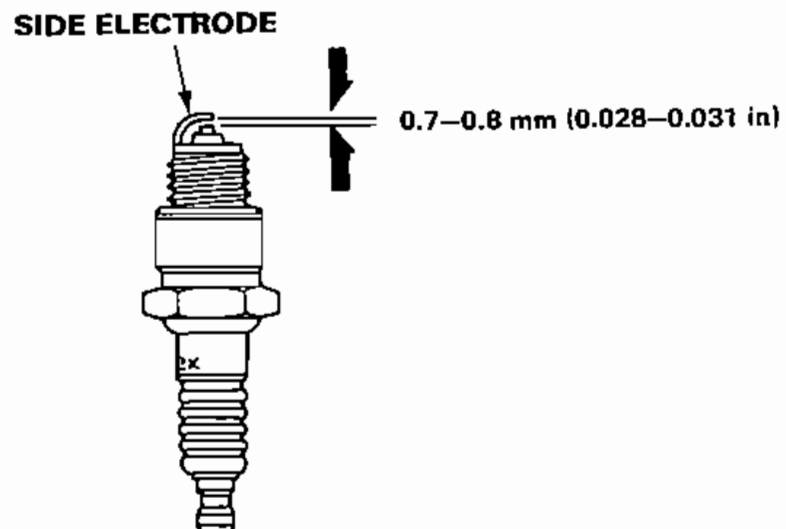

-
7. Attach the plug washer and thread the plug in by hand to prevent cross threading.
 8. After a new spark plug has been seated by hand, it should be tightened 1/2 turn with a wrench to compress its washer.
If a used plug is being reinstalled, it should only require 1/8 to 1/4 turn after being seated.
 9. Close and latch the rear maintenance cover.

CAUTION:

- **The spark plug must be securely tightened. An improperly tightened plug can become very hot and possibly damage the engine.**
- **Never use a spark plug with an improper heat range.**

Sediment cup

⚠ WARNING Gasoline is extremely flammable and explosive under certain conditions. Do not smoke or allow flames or sparks in the area.

The sediment cup prevents dirt or water which may be in the fuel tank from entering the carburetor. If the engine has not been run for a long time, the sediment cup should be cleaned.

1. Open the left side maintenance cover.
2. Turn the engine switch to the OFF position. Remove the sediment cup by turning it counterclockwise.
3. Clean the cup and rubber gasket in solvent thoroughly.
4. Reassemble the rubber gasket and sediment cup. Tighten securely.
5. Close and latch the side maintenance cover.

⚠ WARNING After installing the sediment cup, check for fuel leaks and make sure the area is dry before starting the engine.

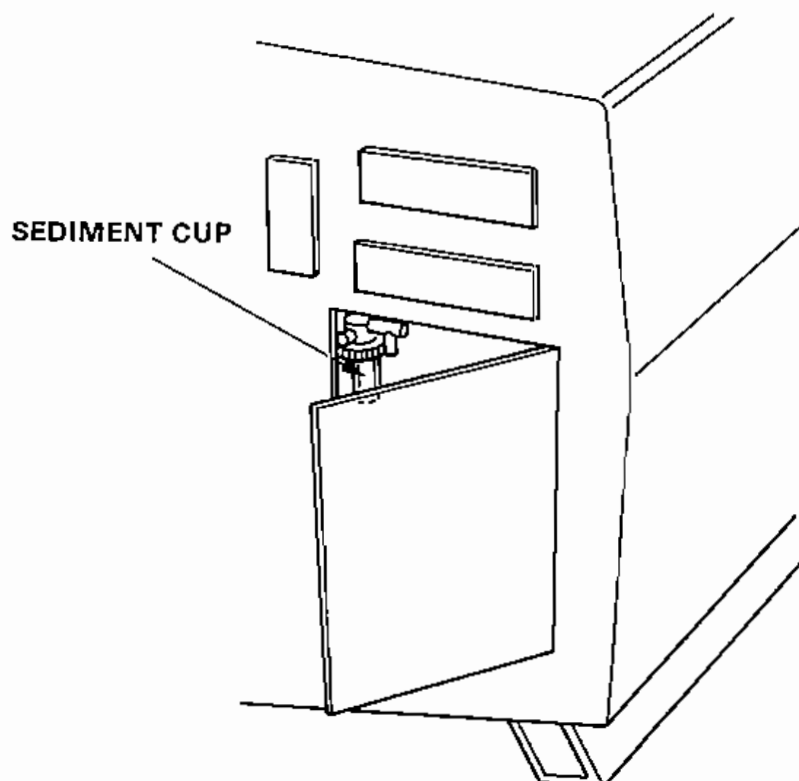

Fuse replacement

If the fuse is blown, the engine will not start until it is replaced.

1. Turn the engine switch OFF.
2. Open the left side maintenance cover, and open the fuse holder cover and replace the fuse. The specified fuses are two 5A and 10A.

CAUTION:

- If frequent fuse failure occurs, determine the cause and correct the problem before attempting to operate the generator further.
- Never use a fuse with a different rating from that specified. Serious damage to the electrical system or fire may result.

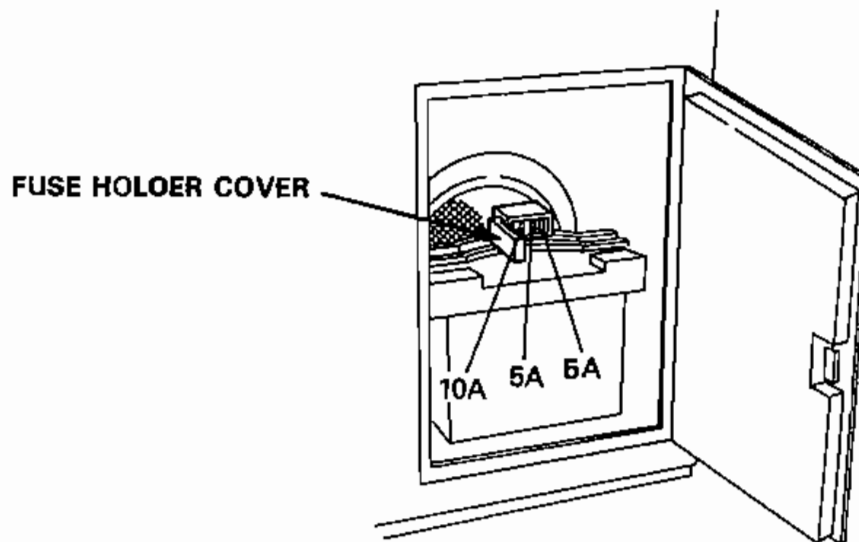

Spark arrester maintenance (Equipped Type only)

⚠ WARNING If the generator has been running, the muffler will be very hot. Allow it to cool before proceeding.

CAUTION: The spark arrester must be serviced every 100 hours to maintain its efficiency.

1. Remove the nine 6 mm bolts, the handle and right side cover.

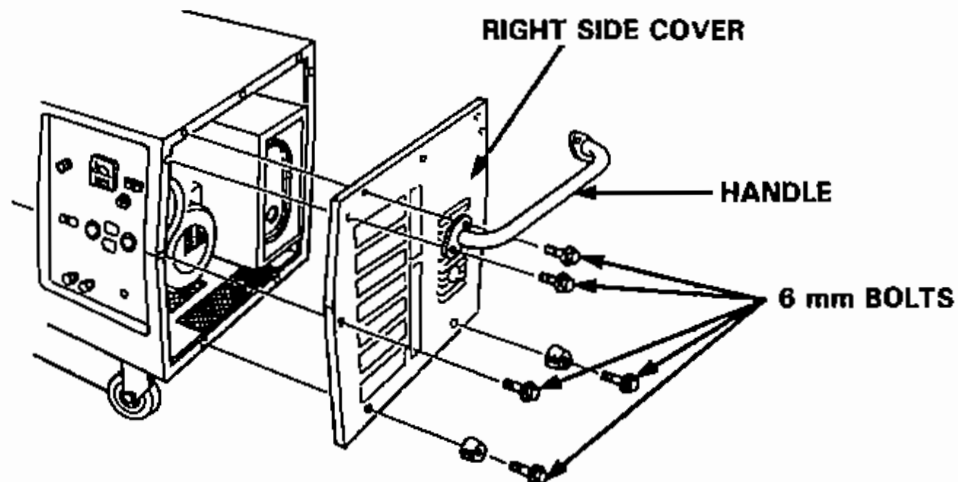

2. Remove the two 5 mm pan screws, and remove the spark arrester.

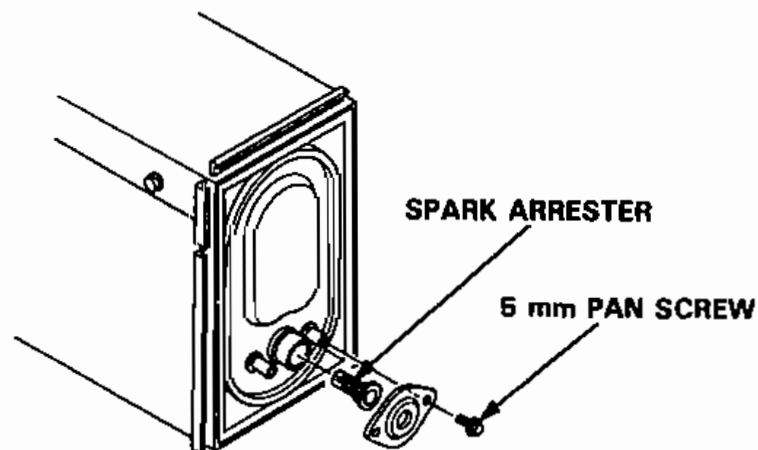

3. Use a brush to remove carbon deposits from the spark arrester screen.

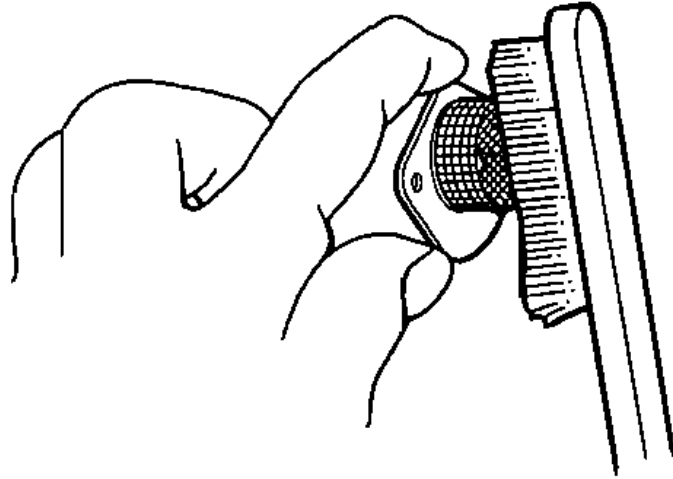

NOTE: Inspect the spark arrester screen for holes or tears. Replace if necessary.

4. Reinstall the spark arrester, right side cover and handle.

9. TRANSPORTING/STORAGE

⚠ WARNING When transporting the generator, turn the engine switch OFF and keep the generator level to prevent fuel spillage. Fuel vapor or spilled fuel may ignite.

Before storing the unit for an extended period:

1. Be sure the storage area is free of excessive humidity and dust.
2. Drain the fuel—
 - a. Open the rear maintenance cover.
 - b. Turn the engine switch to ON and then loosen the carburetor drain screw. Drain the gasoline from the carburetor and fuel tank into a suitable container.

⚠ WARNING Gasoline is extremely flammable and is explosive under certain conditions. Perform this task in a well ventilated area with the engine stopped. Do not smoke or allow flames or sparks in the area during this procedure.

- c. Tighten the carburetor drain screw, turn the engine switch to OFF and close the rear maintenance cover.

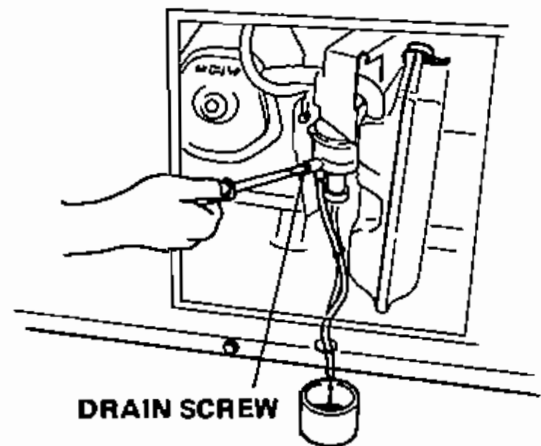

3. Once a month, recharge the battery.

CAUTION: When starting the generator after adding fuel for the first time, after long-term storage, or after running out of fuel, turn the engine switch to the "ON" position, then wait for 10 to 20 seconds before starting the engine.

10. TROUBLESHOOTING

When the engine will not start:

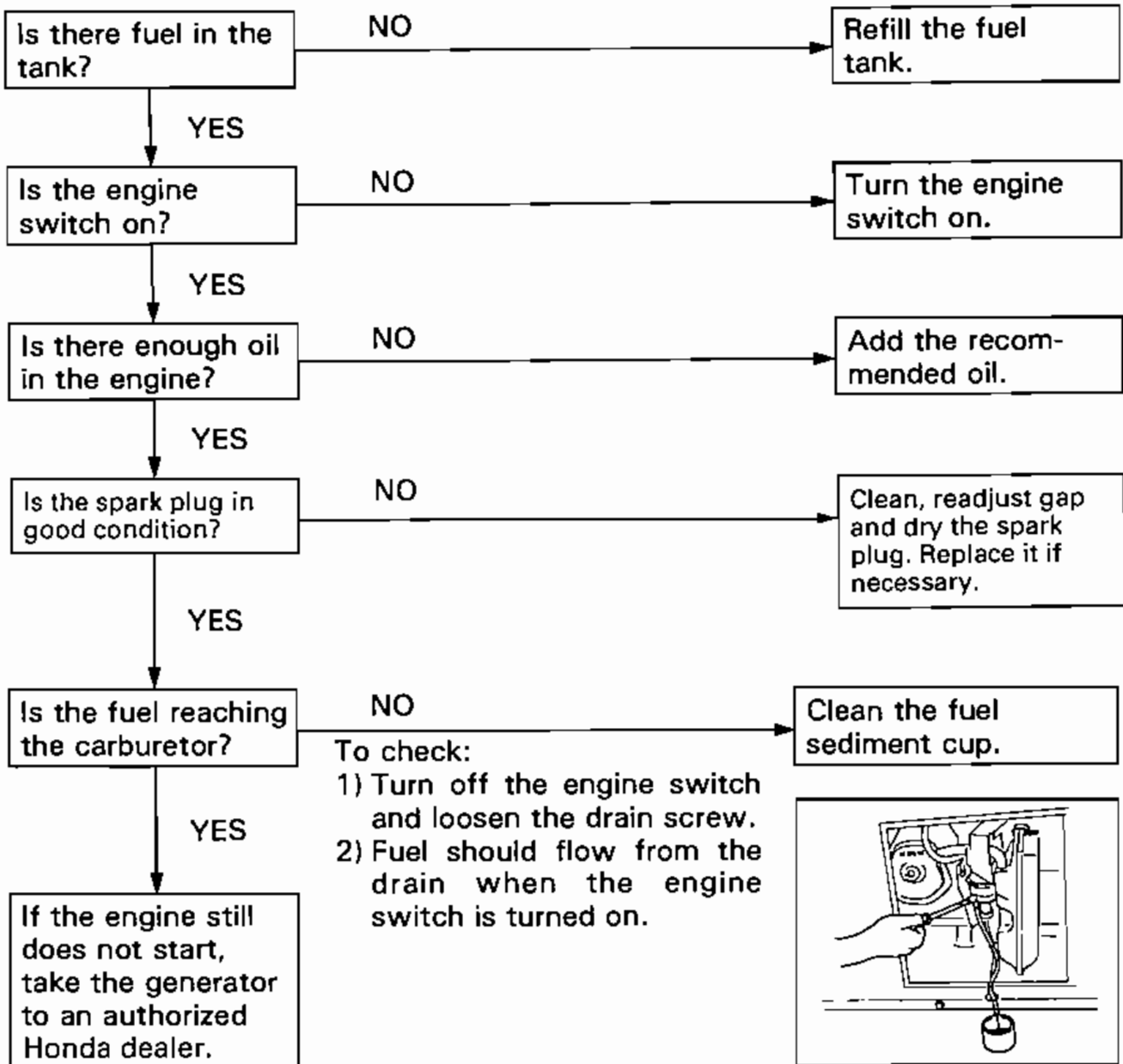

No electricity at the AC receptacles:

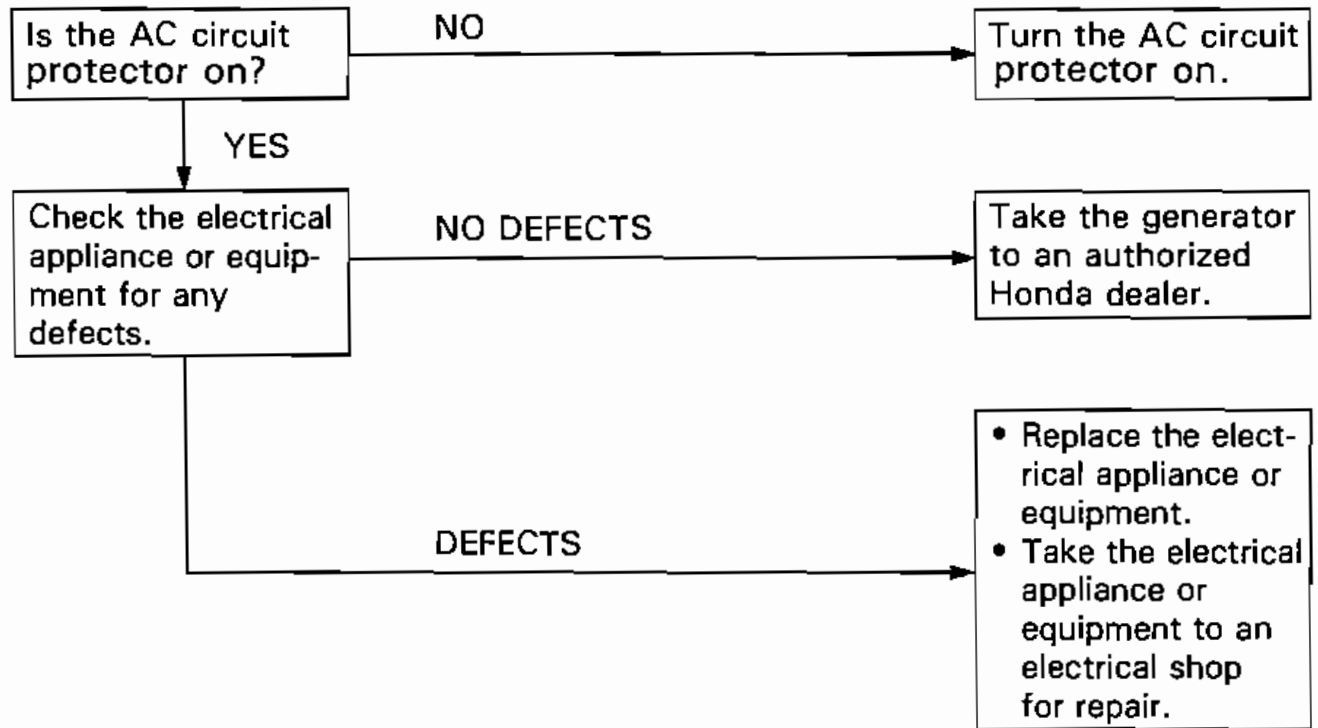

11. OPTIONAL PARTS

Remote Control Kit

The remote control kit is available as optional part to control the generator remotely.

(Installation)

1. Remove the shield cover on the front cover.
2. Disconnect the jumper coupler from the 9-P coupler.
3. Connect the 9-P coupler of the remote control panel to the 9-P coupler disconnected in step 2.
4. Install the remote control panel with four screws.

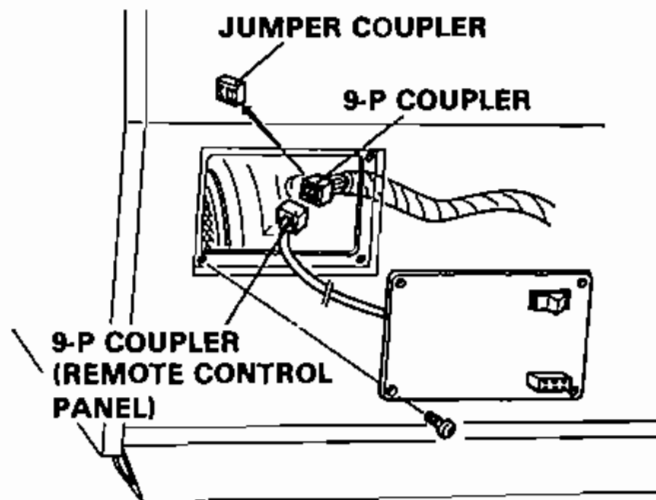

5. Connect the remote control cable coupler to the remote control panel coupler.

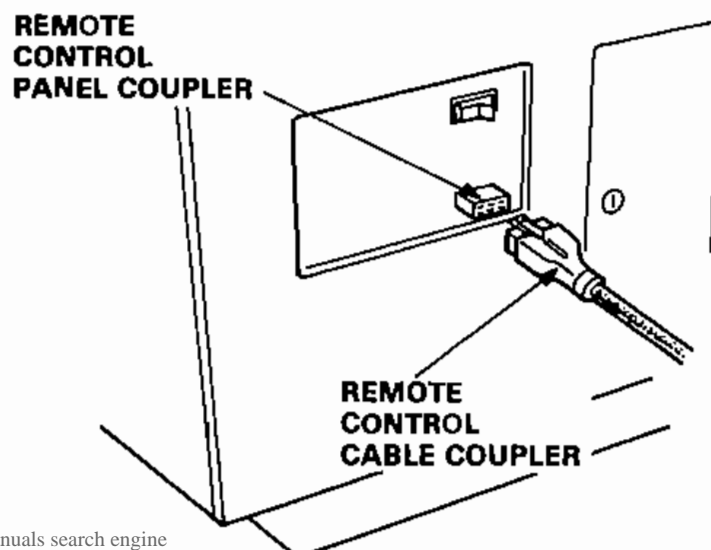

Remote Control Box

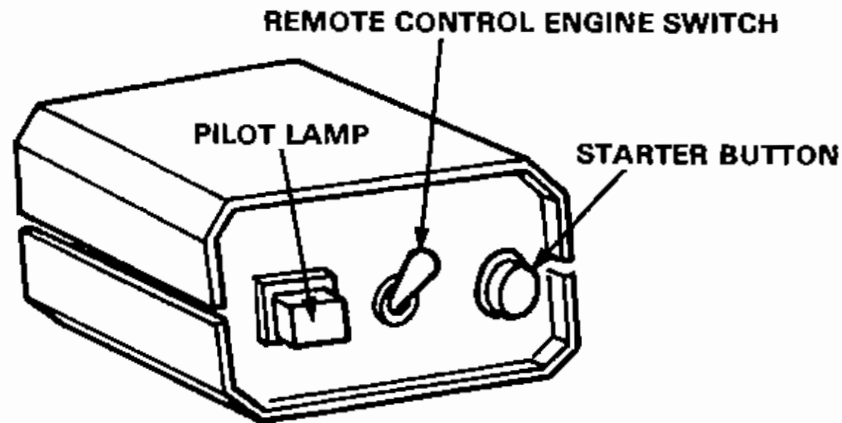

Pilot lamp

The lamp must be on while the engine is rotating.

Remote control engine switch

ON: Flip the knob up to this position to start the engine.

OFF: Flip the knob down to this position to stop the engine.

Starter button

To start the engine, press this button in with the engine switch in the ON position.

NOTE: Turn the relay switch OFF to start and stop the engine with the controls on the generator.

STARTING WITH REMOTE CONTROL

1. Make sure the engine switch is OFF .
2. Turn the auto throttle switch to OFF.
3. Turn off the AC circuit protector.
4. Remove the engine switch key from the generator.
5. Turn the remote control switch to ON.
6. Flip the remote control engine switch knob up to ON.
7. Depress the starter button until the pilot lamp is on.

CAUTION: When a remote controller is installed, be sure to set the remote control switch in the OFF position before starting the machine locally.

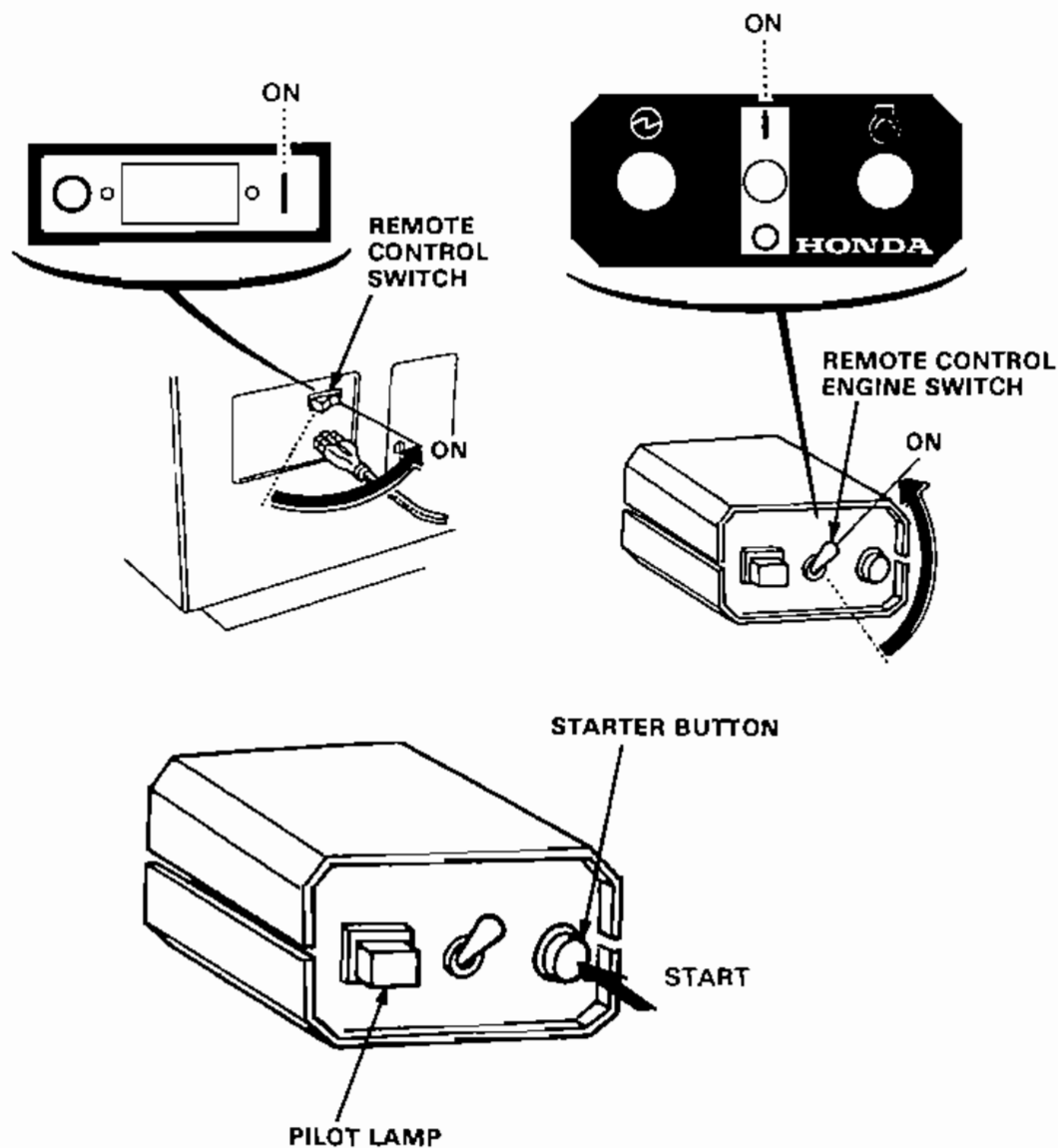

CAUTION: Do not use the starter motor for more than 5 seconds. If the engine fails to start, release the button, and wait at least 10 seconds before operat-

-
8. After the engine starts, turn the auto-throttle switch to AUTO after the engine is warmed up.

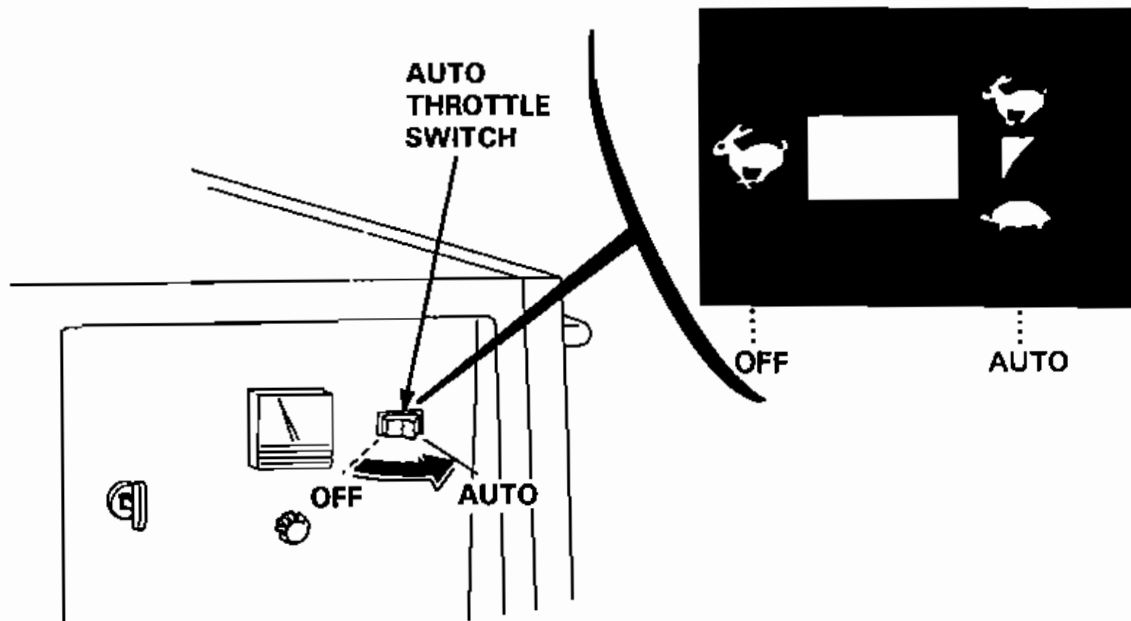

NOTE: The generator employs an automatic choke when the starter motor and battery are used.

9. Generator use (See pages 19-23)

Stopping the engine

1. Turn off the AC circuit protector.
2. Turn the engine switch at the remote control box to the OFF position.
3. Turn the relay box switch to the OFF position.

12. SPECIFICATIONS

EX3300S

Dimensions

Power equipment description code	EB2
Length × Width × Height	910 × 530 × 695 mm (35.8 × 20.9 × 27.4 in)
Dry Weight	109 kg (240.3 lb)

Engine

Model	Honda GX240
Engine Type	4-stroke, O.H.V., 1 cylinder
Displacement {Bore × Stroke}	242 cm ³ (14.8 cu in) [73 × 58 mm (2.9 × 2.3 in)]
Cooling System	Forced air cooling
Ignition System	Transistor Magneto Ignition
Oil Capacity	1.1 ℓ (1.16 US qt, 0.97 Imp qt)
Fuel Tank Capacity	19 ℓ (5.02 US gal., 4.18 Imp gal)
Spark Plug	BPR5ES (NGK), W16EPR-U (DENSO)

Generator

	Model	EX3300S
	Type	L
AC output	Rated voltage	120/240 V
	Rated frequency	60 Hz
	Rated current	25/12.5 A
	Rated output	3.0 kVA
	Maximum output	3.3 kVA
DC output	12 V 8.3 A (Only for charging 12 V automotive batteries.)	

NOTE: Specifications are subject to change without notice due to improvement.

EX4000S·EX4500S

Dimensions

Power equipment description code	EB3
Length × Width × Height	910 × 530 × 695 mm (35.8 × 20.9 × 27.4 in)
Dry Weight	122 kg (269.0 lb)

Engine

Model	Honda GX340
Engine Type	4-stroke, O.H.V., 1 cylinder
Displacement [Bore × Stroke]	337 cm ³ (20.6 cu in) [82 × 64 mm (3.2 × 2.5 in)]
Cooling System	Forced air cooling
Ignition System	Transistor Magneto Ignition
Oil Capacity	1.1 ℓ (1.16 US qt, 0.97 Imp qt)
Fuel Tank Capacity	19 ℓ (5.02 US gal., 4.18 Imp gal)
Spark Plug	BPR5ES (NGK), W16EPR-U (DENSO)

Generator

	Model	EX4000S		EX4500S
	Type	G, GW, F, IT	B	L
AC output	Rated voltage	230 V	115/230 V	120/240 V
	Rated frequency	50 Hz	50 Hz	60 Hz
	Rated current	15.2 A	30.4/15.2 A	33.7/16.7 A
	Rated output	3.5 kVA	3.5 kVA	4.0 kVA
	Maximum output	4.0 kVA	4.0 kVA	4.5 kVA
DC output	Only for charging 12 V automotive batteries. 12V, 8.3A (Except B type)			

Noise

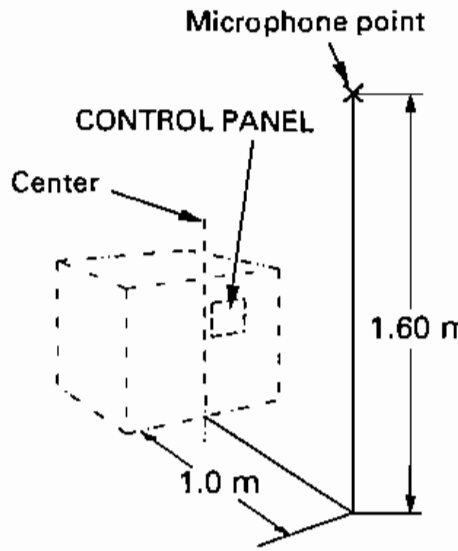
Model	EX4000S		EX4500S
Type	G, GW, F, IT	B	L
<p>Sound pressure level (LpA) According to 98/37/EC</p>  <p>Microphone point</p> <p>CONTROL PANEL</p> <p>Center</p> <p>1.60 m</p> <p>1.0 m</p>	75 dB	75 dB	—
<p>Guaranteed sound power level (LWA) Tested by 2000/14/EC</p>	91 dB	91 dB	—

NOTE: Specifications are subject to change without notice.

13. WIRING DIAGRAM

	Part name
AC CP	AC Circuit Protector
ACOR	AC Output Receptacle
AC, NF	AC Noise Filter
ATS	Auto Throttle Solenoid
ATSw	Auto Throttle Switch
ATU	Auto Throttle Unit
AVR	Automatic Voltage Regulator
BAT	Battery
CBxB	Control Box block
ChC	Charge Coil
CS	Choke solenoid
D	Diode
DC, D	DC Diode
DC, NF	DC Noise Filter
DC, P	DC Protector
DC, T	DC Terminal
DC, W	DC Winding
EgB	Engine Block
ESw	Engine Switch
ExW	Exciter Winding
FrB	Frame Block
FCS	Fuel Cut Solenoid
Fu	Fuse
FV	Fuel Valve
FW	Field Winding
GeB	Generator Block
GT	Ground Terminal
IgC	Ignition Coil
MW	Main Winding
OLSw	Oil Level Switch
OP	Optional Parts
PL	Pilot Lamp
RCBx	Remote Control Box
RCSw	Remote Control Switch
SCUA	Solenoid Control Unit Assembly
SM	Starter Motor
SP	Spark Plug
TS	Thermo Switch
TU	Timer Unit
VAK	Voltage Adjusting Knob
VM	Volt Meter
VSSw	Voltage Selector Switch

Bl	BLACK
Y	YELLOW
Bu	BLUE
G	GREEN
R	RED
W	WHITE
Br	BROWN
Lg	LIGHT GREEN
Gr	GRAY
Lg	LIGHT BLUE
O	ORANGE
P	PINK

EX4000S: B

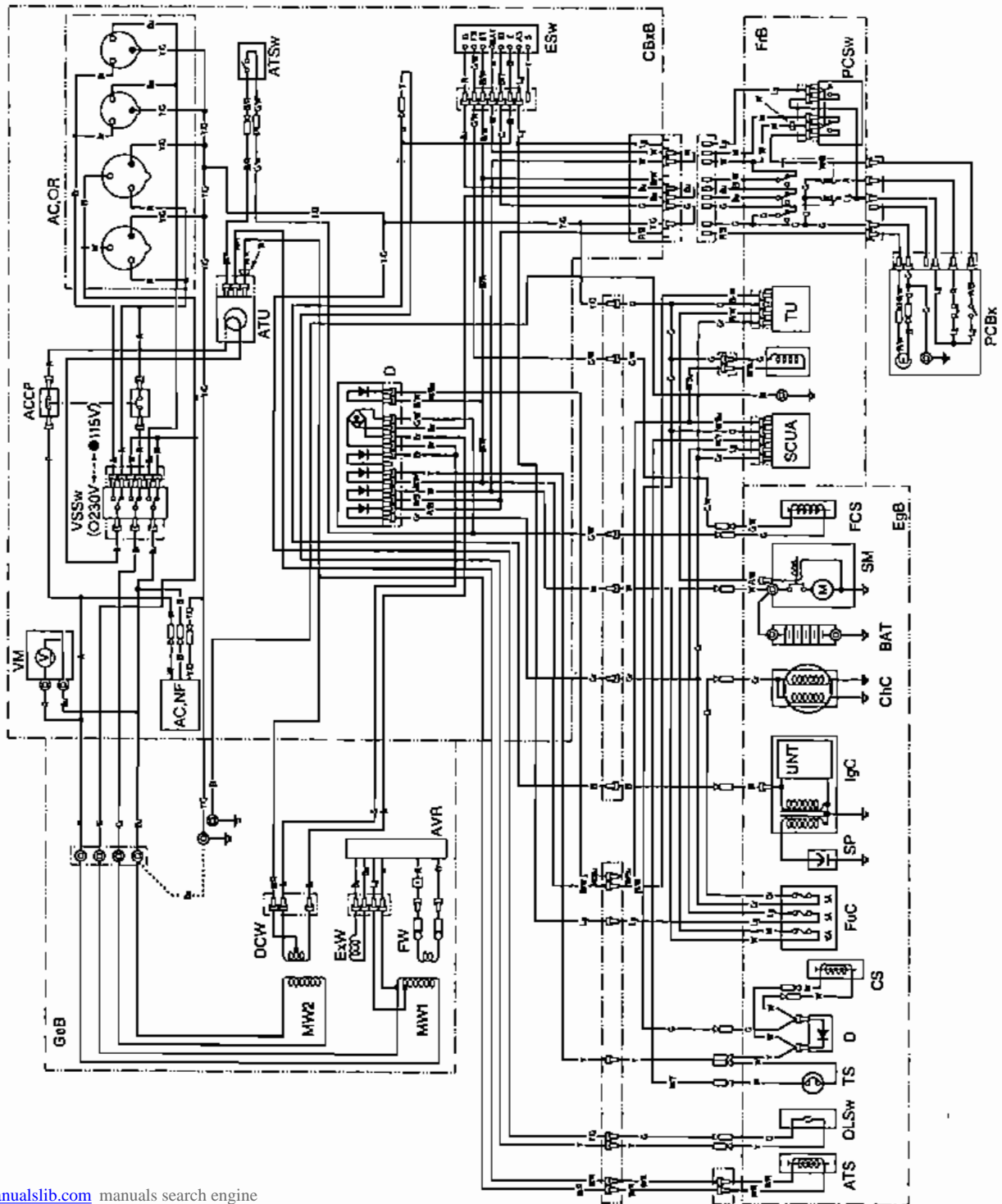

IG	E	M	T	S	F	S	G	A	S
OFF	○	○	○	○	○	○	○	○	○
ON	○	○	○	○	○	○	○	○	○
ST	○	○	○	○	○	○	○	○	○

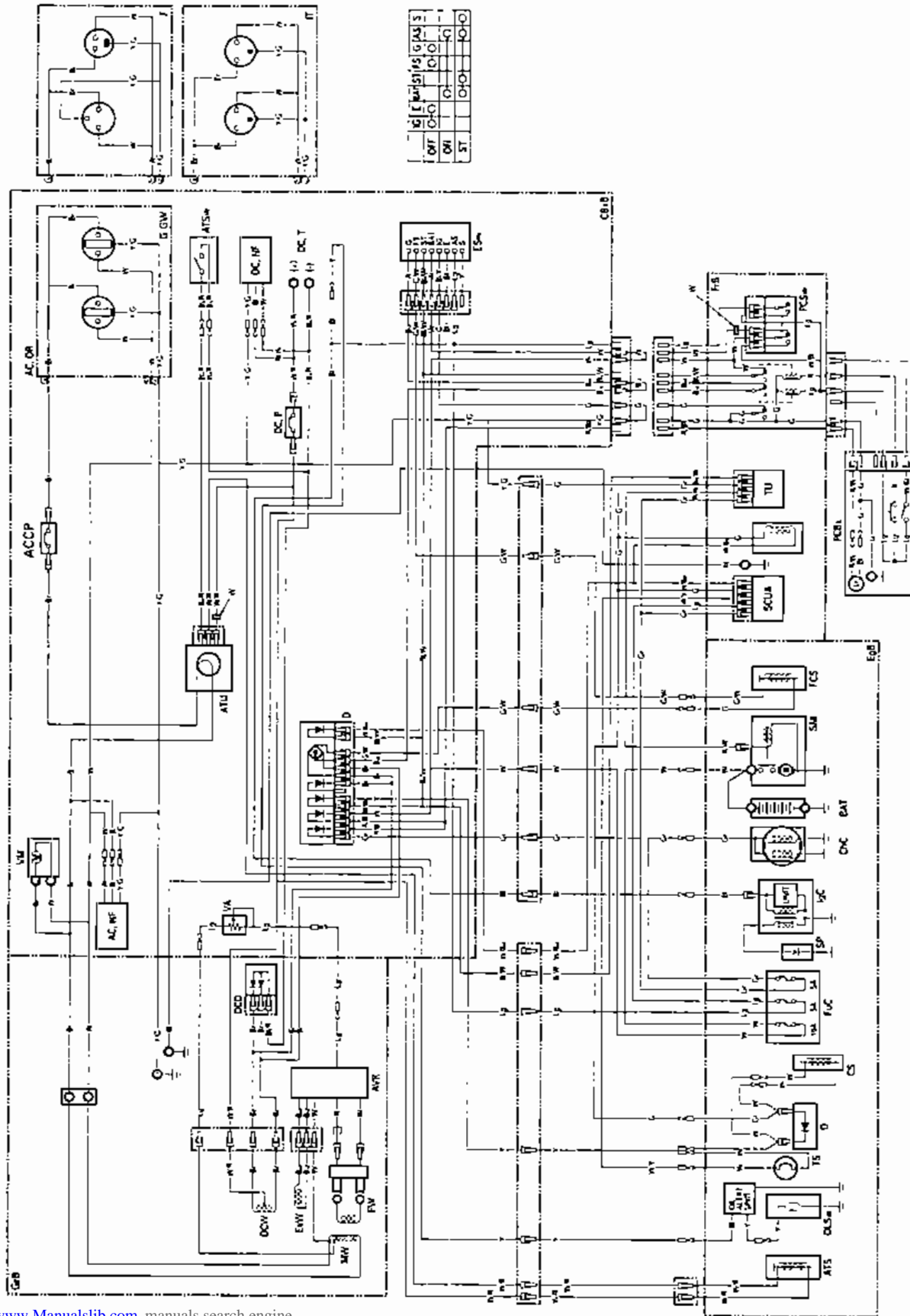

EX4000S: F, G, GW, IT

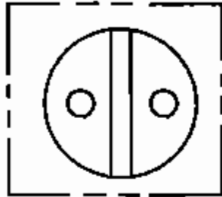
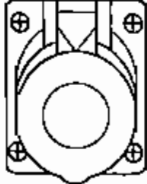
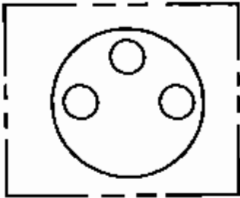
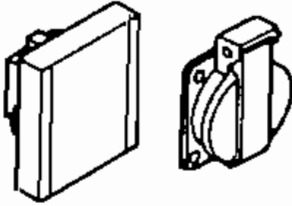
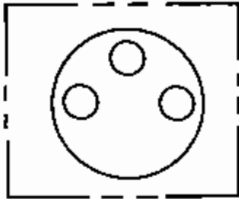
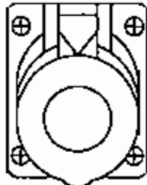
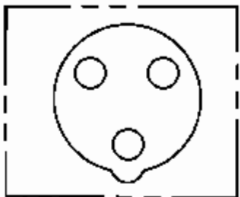
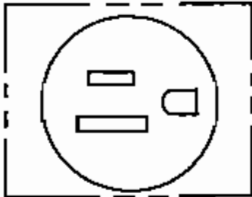

RECEPTACLE

Shape		Type
		G, GW
		B
		F
		IT
		L

14. MAJOR Honda DISTRIBUTOR ADDRESSES

For European

NAME OF FIRM (COMPANY)	ADDRESS	TEL: FAX:
Honda (U.K.) Limited	470 London Road, Slough, Berkshire, SL38QY, United Kingdom	Tel: 01753-590-590 Fax: 01753-590-000
Honda Europe Power Equipment S.A.	Pole 45 Rue des Chataigniers 45140 Ormes France	Tel: 2-38-65-06-00 Fax: 2-38-65-06-02
Honda Motor Europe (North) GmbH.	Spredlinger, Landstraße 166 D-63069 Offenbach/Main Germany	Tel: 069-83-09-0 Fax: 069-83-09-519
Honda Belgium H.V.	Wijngaardveld 1, 9300 Aalst Belgium	Tel: 053-725-111 Fax: 053-725-100
Honda Italia Industriale S.P.A.	Via della Cecchignola, 5/7 00143 ROMA	Tel: 06-54928-1 Fax: 06-54928-400
Honda (Suisse) S.A.	Route des Moulières 10 Case Postale Ch 1214 Vernier-Geneve, Switzerland	Tel: 022-341-22-00 Fax: 022-341-09-72
Honda Nederland B.V.	Capronilaan 1 1119 NN Schiphol-Rijk Netherlands	Tel: 020-7070000 Fax: 020-7070001
Honda Austria G.M.B.H	Honda Strasse 1 A-2351 Wiener Neudorf Austria	Tel: 223-66-900 Fax: 223-66-4130
Honda Power Equipment Sweden A.B.	Ostmästargränd 8 Stockholm-Årsta Sweden	Tel: 08-602-24-60 Fax: 08-722-36-27
Honda Produtos De Força, Portugal, S.A.	Lugar da Abrunheira S. Pedro de Penaferrim 2710 Sintra, Portugal	Tel: 351-1-9150374 Fax: 351-1-9111021
Berema A/S	Berghagan 5, Langhus Box 454, 1401 Ski Norway	Tel: 64-86-05-00 Fax: 64-86-05-49

For European (cotinued)

NAME OF FIRM (COMPANY)	ADDRESS	TEL: FAX:
OY Brandt AB	Tuupakantie 4 SF-01740, Vantaa Finland	Tel: 90-895-501 Fax: 90-878-5276
TIMA PRODUCTS A/S	Tårnfalkevej 16, Postboks 511 DK 2650 Hvidovre Denmark	Tel: 31-49-17-00 Fax: 36-77-16-30
Greens	Polig. Industrial Congost 08530, La Garriga (Barcelona), Spain	Tel: 93-871-84-50 Fax: 93-871-81-80
Automocion Canarias S.A. (AUCASA)	Apartado de Correos, num 206 Santa Cruz de Tenerife Canary Island	Tel: 922-61-13-50 Fax: 922-61-13-44
The Associated Motors Company Ltd.	148, Rue D'Argens, Msida Malta	Tel: 356-333001 Fax: 356-340473
Two Wheels Ltd.	Crosslands Business Park, Ballymount Road, Dublin 12, Ireland	Tel: 4602111 Fax: 4566539
General Automotive Co., S.A.	P.O. Box 1200, 101 73 Athens Greece	Tel: 346-5321 Fax: 346-7329
BG Technik s.r.o	Radlická 117/520 158 01 Praha 5 Czech Republic	Tel: 2-5694 573 Fax: 2-5694 571
Aries Power Equipment Ltd.	01-493 Warszawa, ul Wroclawska 25a Poland	Tel: 22-685 17 06 Fax: 22-685 16 03
MO.TOR.PEDO Ltd.	2040 Buda-rs, Kamaraerdei-t 3. Hungary	Tel: 23-444-971 Fax: 23-444-972

For Australian

NAME OF FIRM (COMPANY)	ADDRESS	TEL: FAX:
Honda Australia Motorcycle and Power Equipment Pty. Ltd	1954-1956 Hume Highway Campbellfield Victoria 3061	Tel: (03) 9270 1111 Fax: (03) 9270 1133

HONDA
POWER PRODUCTS

GENERATOR

EX3300S • EX4000S • EX4500S

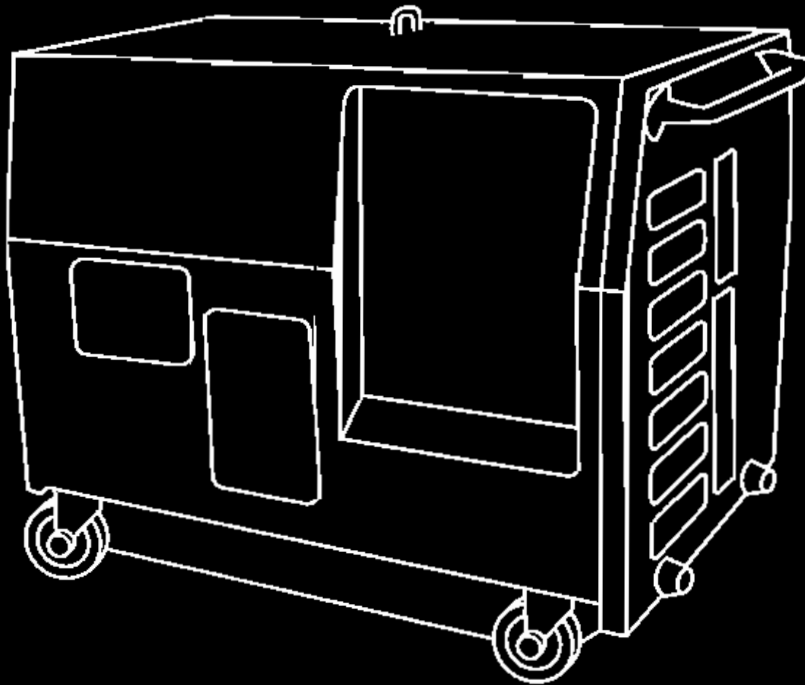

OWNER'S MANUAL
MANUEL DE L'UTILISATEUR
BEDIENUNGSANLEITUNG

HONDA

The Power of Dreams

